

CASH VALVE TYPE D-53 CONTROL VALVES

A pressure operated diaphragm type control valve designed to control the flow of a fluid or air by an independent pressure applied to the valve diaphragm



FEATURES

- Available either normally open; closed by diaphragm pressure or normally closed; opened by diaphragm pressure.
- Diaphragm pressure connection can be indexed to over inlet, over outlet or over either side for maximum hook-up flexibility.
- Full port diameter means full capacity and low pressure drop through the valve.
- Larger sizes have a fully balanced inner valve for both inlet and outlet pressures up to 250 psi, ensuring operating pressure requirements unchanged by variations in system pressure.
- Larger size valve component interchangeability enables easy changeover from normally open to normally closed or vice versa.

GENERAL APPLICATION

Suitable for service with water, air, oil or any non-corrosive fluid as a control valve for water cooled air compressors, an air compressor dump valve, an explosive atmosphere valve or as a substitute for expensive electric solenoids.

TECHNICAL DATA

Materials: Bronze
 Sizes: 1/2", 3/4", 1", 1 1/4", 1 1/2", 2"
 (15, 18, 25, 32, 38, 50 mm)
 Connections: Threaded NPTF
 Pressure range: 0 to 250 psig (0 to 17.2 barg)^[1]
 Max. temperature: 180°F (82°C)

NOTE

1. The maximum diaphragm loading pressure must not exceed 300 psig (20.7 barg).

CASH VALVE TYPE D-53 CONTROL VALVES

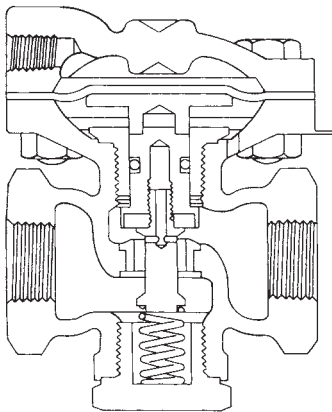

3/4" Type D-53
Normally open

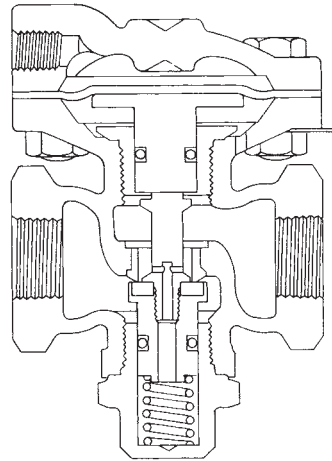

3/4" Type D-53
Normally closed

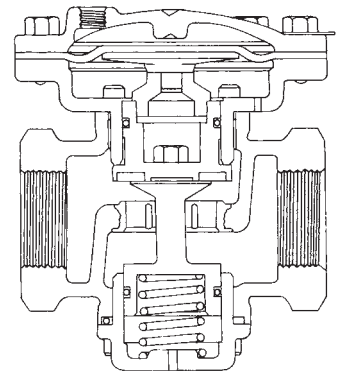

1 1/2", 2" Type D-53
Normally open

CONSTRUCTION/SPECIFICATIONS

The Type D-53 control valve is fitted with a bronze body, renewable 303 stainless steel plated valve seat of full port diameter, a renewable NBR composition seat disc, NBR nylon diaphragm and rust resistant steel bolts.

DIAPHRAGM PRESSURE REQUIREMENTS* (to fully open or fully close valve)

Inlet pressure (psi)	Normally closed valve (pressure to fully open [psi])	Normally open valve (pressure to fully close [psi])
0	20	20
50	20	25
100	20	30
150	20	35
200	20	40
250	20	45

NOTE

Diaphragm pressure requirements for 1 1/2" and 2" sizes are 20 psi to fully open a normally closed valve and 20 psi to fully close a normally open valve.

* Open for 1/2" thru 1 1/4" sizes.

Size	Top connection*	Dimensions				Ship. wt. (lbs)
		A	B **	C N.O.	C N.C.	
1/2"	1/8"	2 7/8"	1 5/16"	1 7/16"	1 7/8"	3
3/4"	1/8"	2 7/8"	1 5/16"	1 7/16"	1 7/8"	3
1"	1/4"	5 7/8"	3 1/2"	2 7/8"	2 7/8"	7
1 1/4"	1/4"	5 7/8"	3 1/2"	2 7/8"	2 7/8"	7
1 1/2"	1/4"	5 7/8"	4"	2 7/8"	2 7/8"	19
2"	1/4"	5 7/8"	4"	2 7/8"	2 7/8"	19

* Top connection extends vertically upward on 1" thru 2" body sizes.

** "B" dimension extends to the height of the top connection on 1" thru 2" body sizes.

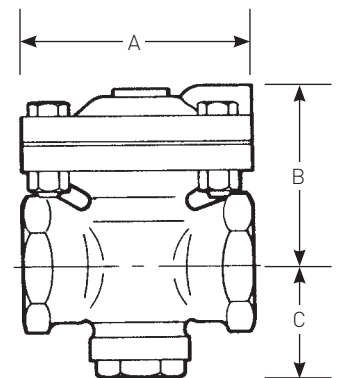

Type D-53
Normally closed

CASH VALVE TYPE D-53 CONTROL VALVES

CAPACITY INFORMATION

HOW TO FIND WATER CAPACITY

1. Determine the pressure drop (psi) across the valve (inlet pressure minus outlet pressure).
On the graph, locate this valve on the pressure drop ordinate.
2. Locate the given gpm capacity on the water flow ordinate.
3. Draw a horizontal line from the pressure drop point and a vertical line from the flow capacity point and mark their intersection. Select the diagonal valve sizing line to the right of this intersection point. Either of the two sizes is the correct valve for the given service conditions.
Do not select a valve size to the left of an intersection point.

Example: given inlet pressure 20 psi, outlet pressure 10 psi, flow 20 gpm.

- (1) Pressure drop = 10 psi. Locate this point on the pressure drop ordinate.
- (2) Locate the 20 gpm point on the water flow ordinate.
- (3) The 10 psi horizontal pressure drop line and the vertical 20 gpm water flow line intersect between the 1/2" - 3/4" and 1" - 1 1/4" sizing lines.

The closest valve size to the right of the intersection point is the 1" or 1 1/4" size.
Select either of these two sizes.

- (4) Maximum valve capacity = 38 gpm.

NOTES

1. Consult the factory for valve sizing with pressure drops greater than 100 psi.
2. Maximum capacity of a selected valve size is found by drawing a horizontal line from the already determined intersection point to the valve sizing line. From this new point, draw a vertical line down to water flow ordinate.
The maximum capacity of the valve is where this vertical line intersects the water flow ordinate.

WATER CAPACITY CHART

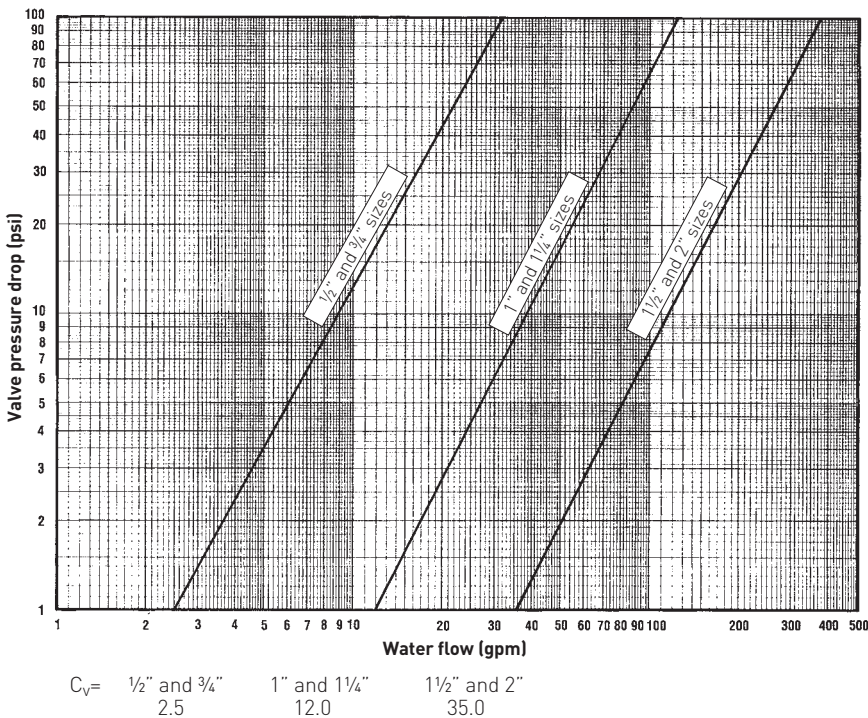

CASH VALVE TYPE D-53 CONTROL VALVES

CAPACITY INFORMATION

HOW TO FIND AIR CAPACITY

- Determine the pressure drop (psi) across the valve (inlet pressure minus outlet pressure). On the graph, locate this valve on the pressure drop ordinate.
- Locate the given scfm capacity point on the air flow ordinate.
- Draw a horizontal line from the pressure drop point and a vertical line from the flow capacity point and mark their intersection. Select the group of curves to the right of the intersection point. The inlet pressure curve must always be to the right of the intersection point. If not, the valve size must be obtained from the next group of inlet pressure curves – to the right of the intersection point.

Example: given inlet pressure 20 psi, outlet pressure 10 psi, flow 200 scfm.

- Pressure drop is 10 psi. Locate this point on the pressure drop ordinate.
- Locate the flow of 200 scfm on the air flow ordinate.
- Mark the point where the 10 psi and 200 scfm lines intersect. Notice the intersection point is to the right of the inlet pressure curve of 20 psi. Therefore, a 1" or 1 1/4" valve should not be selected. Rather, a 1 1/2" or 2" valve should be chosen from the next group of inlet pressure curves - to the right of the intersection point.
- Maximum valve capacity = 540 scfm.

NOTES

- Consult the factory for valve sizing with pressure drops greater than 100 psi.
- Inlet pressure curves for pressures other than 10, 25, 50 or 100 psi should be spaced proportionately and drawn parallel to the given higher and lower inlet pressure curves.
- Maximum valve capacity is found by drawing a horizontal line from the intersection point to the valve size inlet pressure curve. From this new point draw a vertical line down to the air flow ordinate. The maximum capacity of the valve is where this vertical line intersects the air flow ordinate.

AIR CAPACITY CHART

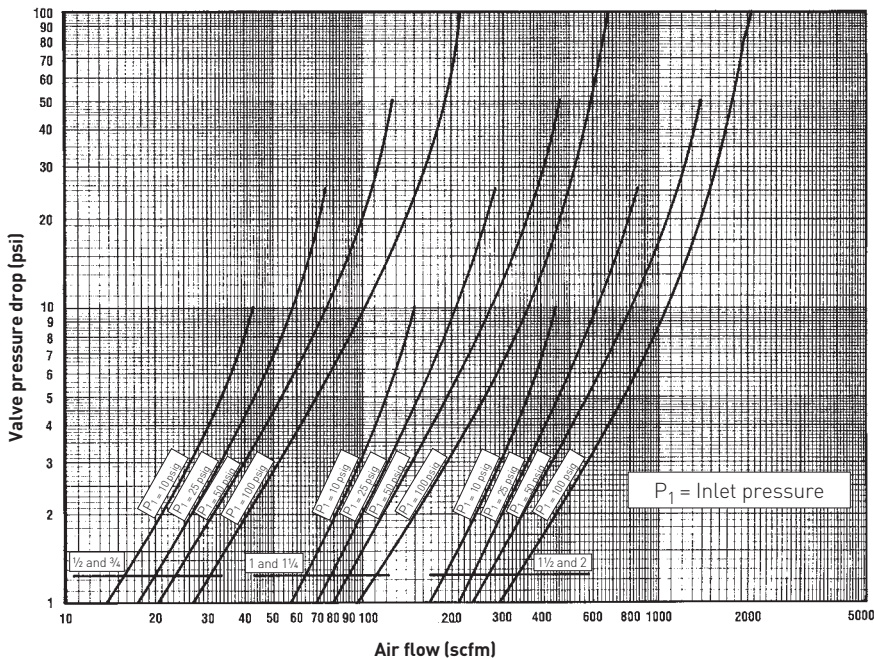

CASH VALVE TYPE D-53 CONTROL VALVES

CAPACITY INFORMATION

SELECTION GUIDE

Example:	D53	C	W	S	O	B	B	01	-	E
Model	D53									
D53	D53 bronze control valve									
Valve size										
C	1/2"	F	1/4"							
D	3/4"	G	1 1/2"							
E	1"	H	2"							
Service										
W	Water/air									
O	Oxygen gas									
Connection style										
S	Side inlet/side outlet - straight thru w/NPT connections									
Seat position										
O	Normally open									
C	Normally closed									
Diaphragm material										
B	NBR									
V	FKM									
Seat material										
B	NBR									
V	FKM									
Variation										
01	Diaphragm chamber connection in line w/inlet									
02	Diaphragm chamber connection right of inlet									
03	Diaphragm chamber connection left of inlet									
04	Minimum flow stop									
Design revision										
(-)	Original design									
Spring material										
E	Stainless steel									



PENTAIR VALVES & CONTROLS

www.pentair.com/valves

All Pentair trademarks and logos are owned by Pentair plc. All other brand or product names are trademarks or registered marks of their respective owners. Because we are continuously improving our products and services, Pentair reserves the right to change product designs and specifications without notice. Pentair is an equal opportunity employer. © 2015 Pentair plc. All rights reserved.