

ADJUSTABLE ANGLE BIMETAL THERMOMETER

Reotemp's Bimetal Thermometers offer dependable and precise temperature monitoring without the need for electricity or wiring. The Industrial Grade is readily available in stock, while the Process Grade offers full customization. With Adjustable Angle Thermometers, you can manually adjust the dial within a 90-degree angle for optimal viewing in any position. These thermometers are ideal for local indication and can be recalibrated with a simple turn of the calibration screw located on the back of the dial.



Industrial Grade Style



Process Grade Style



Fillable



Dials



Accuracy



Custom Logo



FEATURES / BENEFITS

- Five Year Limited Warranty
- Dial Adjusts 90° for Optimal Viewing in Any Position
- Accuracy $\pm 1\%$ Full Scale. (ASME B40.3)
- Hermetically Sealed (ASME B40.3)
- Standard External Reset for Easy Calibration
- Fully Customizable Dials Available
- Silicone Fillable for Vibration Available

SPECIFICATIONS

Accuracy	$\pm 1\%$ Full Scale (ASME B40.3)
Dial Size	3", 4" or 5"
Dial Material	Black marks on satin matte aluminum finish, Hi-Vis™, or white dial
Stem Length	2" to 80"
Stem Diameter	1/4" (Standard), 3/8" or 5/16"
Head, Bezel, Mounting Bushing, Stems	300 Series SS, 316SS (Optional)
Operating Conditions	Head temperature should not exceed 200°F (150°F if silicone filled). Stem should not be exposed to continuous temperatures exceeding 50% over-range or 800°F (550°F if silicone filled).
Environmental Protection	IP67, NEMA 6 Rated (Hermetically sealed per ASME B40.3)
Lens	Glass (Standard), Acrylic, Polycarbonate, Laminated Safety Glass or Tempered Glass
Immersion	Minimum 2" in liquid, and 4" in gas for most ranges. Certain ranges require up to 4" in liquids & 5" in gas.
Mounting Connection	1/2" NPT (Standard), 1/4" NPT, 3/4" NPT, Plain Hex Bushing, or 1/2" BSPT
Temperature Sensing Area	Last 2" to 4" of the stem

ADJUSTABLE ANGLE BIMETAL THERMOMETER

Industrial Grade Style

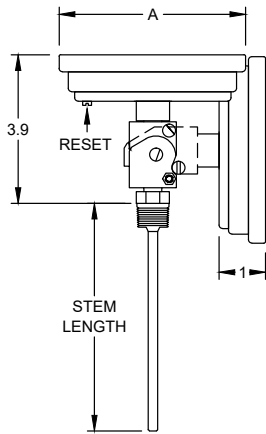

Model	Dial Size	Connection	A
LO	3"	1/2" NPT	3.3"
MO	4"	1/2" NPT	4.3"
JO	5"	1/2" NPT	5.3"

All dimensions are in inches.

Process Grade Style

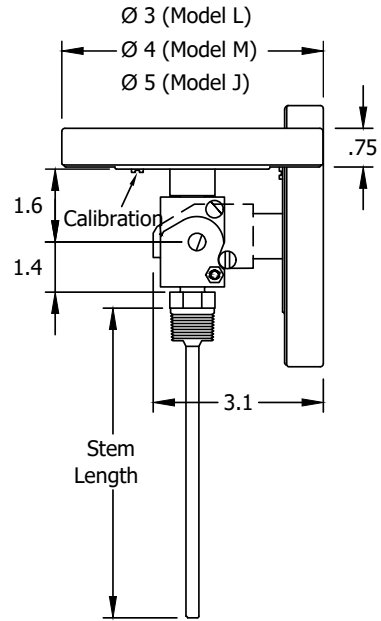

All dimensions are in inches.

ADJUSTABLE ANGLE BIMETAL THERMOMETER

HOW TO ORDER: Choose options to build a part number. For example: LL0251F23-WD-SF

LL	025	1	F23-WD	-SF
DIAL SIZE	STEM LENGTH	CONNECTION	TEMPERATURE RANGE	OPTIONS
<i>Industrial Grade</i>	<i>Industrial Grade</i>	<i>Industrial Grade</i>	<i>Industrial Grade</i>	<i>Industrial Grade</i>
LO = 3" Dial w/ Reset MO = 4" Dial w/ Reset JO = 5" Dial w/ Reset	025 = 2.5" 040 = 4" 060 = 6" 090 = 9" 120 = 12"	1 = 1/2" NPT	Fahrenheit Ranges F39-WD = 0°F to 150°F F47-WD = 0°F to 250°F F63-WD = 50°F to 300°F F69-WD = 50°F to 550°F F85-WD = 200°F to 1000°F <i>For Additional Custom Ranges See Master Range Code Sheet on 391</i>	Tags and Accessories -TS = Tag, Stainless -TP = Tag, Paper -TM = Stainless Steel Tag (11-80 Characters) -HT = Heat Transfer Compound <i>For Additional Options Choose Process Grade</i> <i>For Thermowells See Pages 407-413</i>
<i>Process Grade</i>	<i>Process Grade</i>	<i>Process Grade</i>	<i>Process Grade</i>	<i>Process Grade</i>
LL = 3" Dial w/ Reset MM = 4" Dial w/ Reset JJ = 5" Dial w/ Reset	025 = 2.5" 040 = 4" 060 = 6" 090 = 9" 120 = 12" 150 = 15" 180 = 18" 240 = 24" 300 = 30" 360 = 36" Note: Intermediate stem lengths available up to 80". Millimeter Stem Lengths M???? = Use a code beginning in M to specify a mm stem length ex: 100mm = M0100	1 = 1/2" NPT 4 = 1/4" NPT 5 = 3/4" NPT Adapter X = Plain Unthreaded Hex Bushing U = 1/2" NPT Union	Fahrenheit Ranges F23 = -40°F to 160°F F55 = 25°F to 125°F* F43 = 0°F to 200°F F47 = 0°F to 250°F F63 = 50°F to 300°F F67 = 50°F to 500°F F69 = 50°F to 550°F F81 = 150°F to 750°F F85 = 200°F to 1000°F Celsius Ranges C23 = -40°C to 70°C C55 = 0°C to 50°C* C43 = 0°C to 100°C C47 = -20°C to 120°C C59 = 0°C to 150°C C67 = 0°C to 250°C C69 = 0°C to 300°C C73 = 0°C to 400°C C85 = 100°C to 500°C Dual Scale Ranges D23 = -40°F to 160°F & -40°C to 70°C D55 = 25°F to 125°F & -5°C to 50°C* D43 = 0°F to 200°F & -10°C to 90°C D47 = 0°F to 250°F & -20°C to 120°C D63 = 50°F to 300°F & 10°C to 150°C D67 = 50°F to 500°F & 10°C to 260°C D69 = 50°F to 550°F & 10°C to 290°C D81 = 150°F to 750°F & 70°C to 400°C D85 = 200°F to 1000°F & 100°C to 500°C *Not available in 2.5" stem. <i>For Additional Ranges See Master Range Code Sheet on Page 391</i>	General Options -3H = 316 SS Head and Bezel -PS = Pointed Stem -SF = Silicone Filled -SS = 316 Stainless Stem -WD = White Dial -HV = Hi-Vis™ Dial -NL = No Logo Dial -CB = Color Bands -PI = Color Pie -CL = Custom Logo Dial Window Options (Standard is Glass) -MM = Min-Max Pointer (Plastic Lens) -PC = Acrylic Window -PY = Polycarbonate Window -TG = Tempered Glass Window -SG = Laminated Safety Glass Calibration Cert. Options -R1 = One Point Calibration Cert (Reotemp Chooses Points) -R3 = Three Point Calibration Cert (Reotemp Chooses Points) Tags and Accessories -TS = Tag, Stainless -TP = Tag, Paper -AS = Adapts Bimet to 1-1/4-18 industrial Socket -HT = Heat Transfer Compound <i>For Additional Options See Page 390</i> <i>For Thermowells See Pages 407-413</i>

Note: Thermowells should be used whenever the stem or bulb would be exposed to pressure, corrosion, velocity, abrasion or shear forces. Thermowells also make it possible to remove the thermometer without losing pressure or the contents of the process.

THREADED THERMOWELLS

Reotemp Threaded Thermowells make it possible to remove an instrument without dropping pressure or losing contents of the process. Thermowells also protect the instrument from getting bent by the process media. Threaded thermowells are perfect for applications that require infrequent replacement and are commonly installed on smaller pipes or vessels. They are best suited for non-corrosive media. Reotemp threaded thermowells are machined from solid bar stock.



Threaded



FEATURES / BENEFITS

- Machined from Solid Material
- Protects Your Instrument from the Process
- Easy Removal of Instrument for Calibration or Replacement

OPTIONS

- Wake Frequency Calculation
- Hydrostatic Test
- NACE Certified
- Material Certificate
- Special Marking (Stamping)
- Plug & Chain
- PMI

Standard

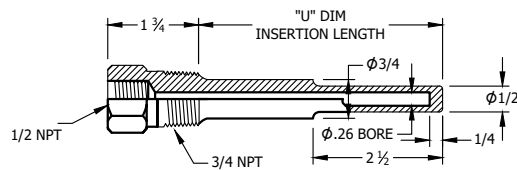

All dimensions are in inches.

Standard Dimensions

Stem "A"	Standard "U"	Lagging "U"	Overall Length
2.5"	1.625"	N/A	2.875"
4"	2.5"	N/A	4.25"
6"	4.5"	2.5"	6.25"
9"	7.5"	4.5"	9.25"
12"	10.5"	7.5"	12.25"

Lagging

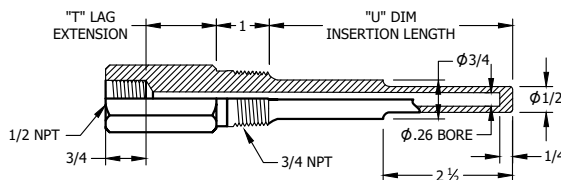

All dimensions are in inches.

THREADED THERMOWELLS



Visit reotemp.com

- ✓ Check Stock
- ✓ Get Price
- ✓ Configure Part #
- ✓ Generate a Custom Engineering Drawing

HOW TO ORDER: Choose options to build a part number. For example: **ST6316-ML**

TYPE	"A" STEM LENGTH	MATERIAL	PROCESS CONNECTION	SHANK	BORE DIAMETER	OPTIONS
ST = Threaded	2.5 = 2.5"	304 = 304SS	" " = 3/4" NPT (std.)	" " = Stepped (std.)*	" " = .260 (std.)	EP = External Pressure Test
LG = Threaded Lagging	4 = 4" 6 = 6" 9 = 9" 12 = 12"	316 = 316SS 316L = 316L SS B = Brass C = Carbon Steel (1018) G = Hastelloy B H = Hastelloy C M = Monel/A400 T = Titanium Y = Inconel 600 A = Alloy 105 Carbon Stainless Steel D = Alloy 20 5 = F5 Alloy P = PTFE Coated 316SS N = F22 Alloy	1 = 1" NPT H = 1/2" NPT 2 = 1.5" NPT	T = Tapered S = Straight *Not available with .385 bore.	B3 = .385 B5 = .515 I3 = 3/4" NPT Internal Thread Other bore and internal thread sizes available.	IT = Internal Pressure Testing (5 min. test) MT = Material Certificate ML = Mill Certificate MR = NACE MR-01-75 Approval M3 = NACE MR-01-03 Approval PM = Positive Material Identification (PMI) P4 = SS 304 Plug & Chain P6 = SS 316 Plug & Chain PB = Brass Plug & Chain R2 = Special Surface Finish (Ra 20 max) T1 = Tantalum Coating/ Halar Coating T2 = Teflon Coating (Specify PFA or PTFE) T3 = Tungsten Carbide Coating TM = Special Marking (Stamping) TS = SS Tag (attached) WK = Wake Frequency Calculation
		Other materials available. Contact Reotemp customer service for more information.				

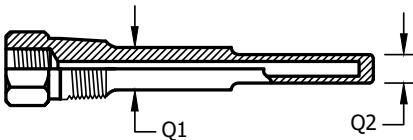

All dimensions are in inches.

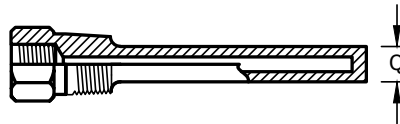

All dimensions are in inches.

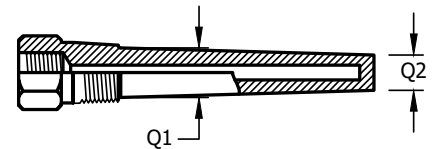

All dimensions are in inches.

Stepped Shank			
Bore Dia.	Ext. Thread Size	Shank Dia. "Q1" (U>2.5)	Shank Dia. "Q2"
.260"	1/2" NPT	.625"	.500"
.260"	3/4" NPT	.750"	.500"
.260"	1" NPT	.875"	.500"

Straight Shank			
Bore Dia.	Ext. Thread Size	Shank Dia. "Q" (U≤2.5)	Shank Dia. "Q" (U>2.5)
.260"	1/2" NPT	.500"	.625"
.260"	3/4" NPT	.500"	.625"
.260"	1" NPT	.750"	.875"
.385"	1/2" NPT	.680"	.680"
.385"	3/4" NPT	.766"	.766"
.385"	1" NPT	.875"	.875"

Tapered Shank			
Bore Dia.	Ext. Thread Size	Shank Dia. "Q1"	Shank Dia. "Q2"
.260"	1/2" NPT	.680"	.625"
.260"	3/4" NPT	.875"	.625"
.260"	1" NPT	1.062"	.625"
.385"	1/2" NPT	.680"	.625"
.385"	3/4" NPT	.875"	.766"
.385"	1" NPT	1.062"	.766"

WELDED THERMOWELLS

Reotemp Welded Thermowells make it possible to remove an instrument without dropping pressure or losing the contents of the process. Thermowells also protect the instrument from getting bent by the process media. Weld-in thermowells are welded directly to a pipe or tank, providing a very high quality connection. Because they are welded, they should only be used when access is not required and corrosion is not an issue. Common installations include high temperature and high pressure applications with non-corrosive media. Reotemp weld-in thermowells are machined from bar stock.



Socket Weld



FEATURES / BENEFITS

- High Quality Connection
- Ideal for High Temperature and High Pressure Applications with Non-corrosive Media
- Socket Weld or Standard Weld-in
- Easy Removal of Instrument for Calibration or Replacement

OPTIONS

- Wake Frequency Calculation
- Hydrostatic Test
- NACE Certified
- Material Certificate
- Special Marking (Stamping)
- Plug & Chain
- PMI

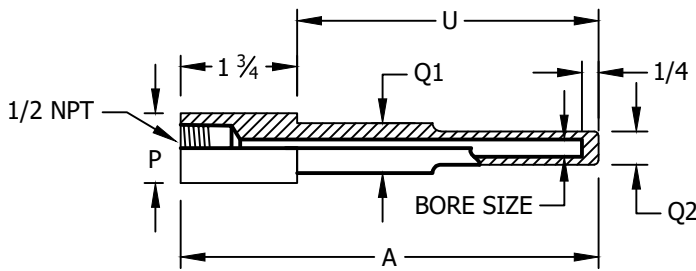

All dimensions are in inches.

Socket Weld Stepped Shank

Bore Dia. "B"	Nominal Pipe Size "P"	O.D. "D"	Shank Dia. "Q1" (U≤2.5)	Shank Dia. "Q1" (U>2.5)	Shank Dia. "Q2"
.260"	3/4"	1.050"	.500"	.750"	.500"
.260"	1"	1.315"	.750"	.875"	.500"
.260"	1.5"	1.900"	1.000"	1.120"	.500"

Socket Weld Straight Shank

Bore Dia. "B"	Nominal Pipe Size "P"	O.D. "D"	Shank Dia. "Q2" (U≤2.5)	Shank Dia. "Q2" (U>2.5)
.260"	3/4"	1.050"	.500"	.750"
.260"	1"	1.315"	.750"	.875"
.260"	1.5"	1.900"	1.00"	1.12"
.385"	3/4"	1.050"	.766"	.766"
.385"	1"	1.315"	.766"	.875"
.385"	1.5"	1.900"	1.00"	1.12"

Socket Weld Tapered Shank

Bore Dia. "B"	Nominal Pipe Size "P"	O.D. "D"	Shank Dia. "Q1"	Shank Dia. "Q2"
.260"	3/4"	1.050"	.750"	.625"
.260"	1"	1.315"	1.000"	.625"
.260"	1.5"	1.900"	1.370"	.625"

WELDED THERMOWELLS



Visit reotemp.com

- ✓ Check Stock
- ✓ Get Price
- ✓ Configure Part #
- ✓ Generate a Custom Engineering Drawing

HOW TO ORDER: Choose options to build a part number. For example: **SW6316-P1T-ML**

SW	6	316	-	P1	T	-	ML
TYPE	"A" STEM LENGTH	MATERIAL	PROCESS CONNECTION	SHANK	BORE DIAMETER	OPTIONS	
SW = Socket Weld SWL = Socket Weld w/ Lagging WI = Weld-In WIL = Weld-In w/ Lagging	2.5 = 2.5" 4 = 4" 6 = 6" 9 = 9" 12 = 12"	304 = 304SS 316 = 316SS 316L = 316L SS B = Brass C = Carbon Steel (1018) G = Hastelloy B H = Hastelloy C M = Monel/A400 T = Titanium Y = Inconel 600 A = Alloy 105 Carbon Stainless Steel D = Alloy 20 F = F5 Alloy P = PTFE Coated 316SS N = F22 Alloy Other materials available. Contact Reotemp customer service for more information.	" " = 3/4" Pipe Nominal (1.050" OD) (std.) P1 = 1" Pipe Nominal (1.315" OD) P2 = 1.5" Pipe Nominal P3 = 2" Pipe Nominal	" " = Stepped (std.)* T = Tapered S = Straight *Not available with .385 bore.	" " = .260 (std.) B3 = .385 B5 = .515 I3 = 3/4" NPT Internal Thread Other bore and internal thread sizes available.	EP = External Pressure Test IT = Internal Pressure Testing (5 min. test) MT = Material Certificate ML = Mill Certificate MR = NACE MR-01-75 Approval M3 = NACE MR-01-03 Approval PM = Positive Material Identification (PMI) P4 = SS 304 Plug & Chain P6 = SS 316 Plug & Chain PB = Brass Plug & Chain R2 = Special Surface Finish (Ra 20 max) T1 = Tantalum Coating/ Halar Coating T2 = Teflon Coating (Specify PFA or PTFE) T3 = Tungsten Carbide Coating TM = Special Marking (Stamping) TS = SS Tag (attached) WK = Wake Frequency Calculation	

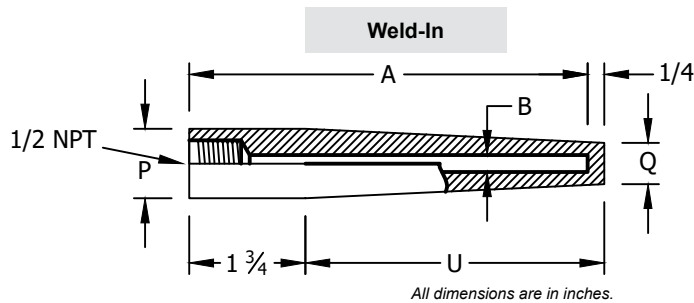

Weld-in Tapered Shank			
Bore Dia. "B"	Nominal Pipe Size "P"	O.D. "D"	Tip Dia "Q"
.260 in	3/4"	1.050"	.625"
	1"	1.315"	.766"
.385 in	3/4"	1.050"	.625"
	1"	1.315"	.766"

FLANGED THERMOWELLS

Reotemp's Flanged Thermowells make it possible to remove an instrument without dropping pressure or losing contents of the process. Thermowells also protect the instrument from getting bent by the process media. Flanged thermowells are the preferred well for applications that require frequent removal or replacement due to corrosion or other hazards. Flanged wells bolt to a mating flange that is installed on the process piping. Common installations include large pipes with high pressure and high corrosion.



FEATURES / BENEFITS

- Die Stamped with Material
- Ideal for High Pressure and High Corrosion Applications Requiring Frequent Replacement
- Easy Removal of Instrument for Calibration or Replacement

OPTIONS

- Wake Frequency Calculation
- Hydrostatic Test
- Full Penetration Welds
- NACE Certified
- Material Certificates
- PMI

Flanged

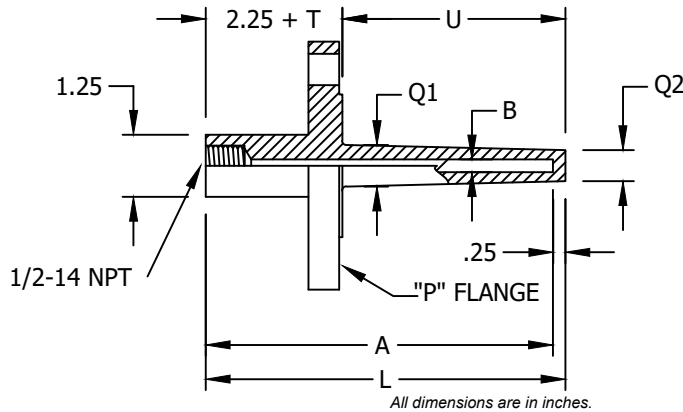

Van Stone

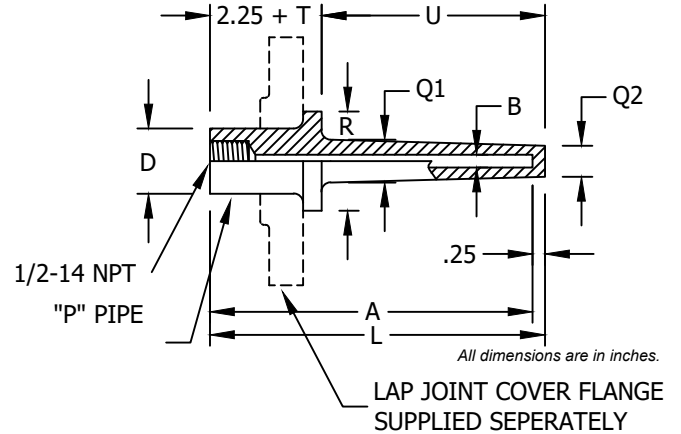

Tapered Shank

Bore Dia. "B"	Flange Size	Shank Dia. "Q1"	Shank Dia. "Q2"
.260"	3/4"	.750"	.625"
.260"	1"	.875"	.625"
.260"	1-1/2" & up	1.062"	.625"
.385"	3/4"	.750"	.625"
.385"	1"	.875"	.766"
.385"	1-1/2" & up	1.062"	.766"

Stepped Shank

Bore Dia. "B"	Shank Dia. "Q1"	Shank Dia. "Q2"
.260"	.750"	.500"

Straight Shank

Bore Dia. "B"	Shank Dia. "Q2"
.260"	.750"
.385"	.875"

Van Stone size

Nominal Pipe Size "P"	O.D. "D"	Raised Face Dia. "R"
1"	1.315"	2.000"
1.5"	1.900"	2.875"

Van Stone

Bore Dia. "B"	Shank Dia. "Q"
.260"	.750"
.385"	.875"

FLANGED THERMOWELLS

HOW TO ORDER: Choose options to build a part number. For example: 151R2STU040L062-ML

FLANGE SIZE	FLANGE RATING	SEALING FACE	BORE DIAMETER	MATERIAL	SHANK STYLE	"U" DIMENSIONS & OVERALL LENGTH																					
05 = 1/2" 07 = 3/4" 10 = 1" 15 = 1.5" 20 = 2" 25 = 2.5" 30 = 3"	1 = 150# 3 = 300# 6 = 600# 9 = 900 - 1500# 5 = 2500# V = VanStone	R = Raised Face F = Flat Face J = RTJ (Ring Type Joint) Q = Other (Specify)	2 = .260" (For 1/4" Stem) 3 = .385" (For 3/8" Stem) Q = Other (Specify) *Not available with .385 bore.	S = 316SS F = 304SS C = Carbon Steel D = Carp. 20/Alloy 20 G = Hastelloy B H = Hastelloy C L = F11 Alloy M = Monel Y = Inconel (600) U = Tantalum Lined Z = Zirconium (316 fig) V = 317SS T = Titanium K = 316/Stellite Coating 2 = Alloy 20 5 = F5 Alloy N = F22 Alloy P = PTFE Coated 316SS	T = Tapered S = Straight P = Stepped* R = Tapered w/ Support Ring Q = Other *Not available with .385 bore.	U040L062	<table border="1"> <thead> <tr> <th>"U" Dimensions</th> <th>Overall Length</th> </tr> </thead> <tbody> <tr><td>U020 = 2"</td><td>L042 = 4.25"</td></tr> <tr><td>U040 = 4"</td><td>L062 = 6.255"</td></tr> <tr><td>U070 = 7"</td><td>L092 = 9.25"</td></tr> <tr><td>U100 = 10"</td><td>L122 = 12.25"</td></tr> <tr><td>U130 = 13"</td><td>L152 = 15.25"</td></tr> <tr><td>U160 = 16"</td><td>L182 = 18.25"</td></tr> <tr><td>U220 = 22"</td><td>L242 = 24.25"</td></tr> <tr><td>U225 = 22.5"</td><td>L247 = 24.75"</td></tr> <tr><td>M250 = 250mm</td><td>M307 = 307mm</td></tr> </tbody> </table>	"U" Dimensions	Overall Length	U020 = 2"	L042 = 4.25"	U040 = 4"	L062 = 6.255"	U070 = 7"	L092 = 9.25"	U100 = 10"	L122 = 12.25"	U130 = 13"	L152 = 15.25"	U160 = 16"	L182 = 18.25"	U220 = 22"	L242 = 24.25"	U225 = 22.5"	L247 = 24.75"	M250 = 250mm	M307 = 307mm
"U" Dimensions	Overall Length																										
U020 = 2"	L042 = 4.25"																										
U040 = 4"	L062 = 6.255"																										
U070 = 7"	L092 = 9.25"																										
U100 = 10"	L122 = 12.25"																										
U130 = 13"	L152 = 15.25"																										
U160 = 16"	L182 = 18.25"																										
U220 = 22"	L242 = 24.25"																										
U225 = 22.5"	L247 = 24.75"																										
M250 = 250mm	M307 = 307mm																										

Note: Rows above indicate standard pairings, for example: a 2" U dimension comes standard with a 4.25" overall length.

-ML

OPTIONS

- EP = External Pressure Test
- IT = Internal Pressure Testing (5 min. test)
- MT = Material Certificate
- ML = Mill Certificate
- MR = NACE MR-01-75 Approval
- M3 = NACE MR-01-03 Approval
- PM = Positive Material Identification (PMI)
- P4 = SS 304 Plug & Chain
- P6 = SS 316 Plug & Chain
- PB = Brass Plug & Chain
- R2 = Special Surface Finish (Ra 20 max)
- T1 = Tantalum Coating/ Halar Coating
- T2 = Teflon Coating (Specify PFA or PTFE)
- T3 = Tungsten Carbide Coating
- TM = Special Marking (Stamping)
- TS = SS Tag (attached)
- WK = Wake Frequency Calculation

Optional Shank Diameters

Code	Dia. in.
A	0.375"
B	0.400"
C	0.500"
D	0.563"
T	0.600"
E	0.625"
F	0.680"
G	0.735"
H	0.750"
J	0.766"
K	0.781"
L	0.860"
7	0.875"
N	0.900"
P	1.000"
8	1.050"
R	1.063"
S	1.125"
6	1.250"
U	1.315"
V	1.375"
9	1.500"
Y	1.625"
Z	1.900"

Optional shank diameters are available on selected thermowells with tapered or straight shanks. Configure your thermowell online to see availability of shank options.

SANITARY THERMOWELLS

Reotemp's Sanitary Thermowells make it possible to remove an instrument without dropping pressure or losing contents. Each stainless steel Thermowell is die stamped with type of material from which it is made. Sanitary wells have a smooth surface (RA32 or Better) and a Tri-Clamp® connection which allows for easy cleaning to prevent contamination of the process. They are used in the Dairy, Food Processing and Pharmaceutical industries.



FEATURES / BENEFITS

- Smooth Surface for Easy Cleaning (RA32 or Better)
- Provides Sanitary Protection for Temperature Probes
- All 316L Stainless Steel Construction
- Fast Installation and Removal
- Ideal for Food, Beverage, Biotech, and Pharmaceutical Applications
- Exceeds 3A #4 Finish
- Easy Removal of Instrument for Calibration or Replacement

HOW TO ORDER: Choose a code to make your selection. For example: **STF1.5-2.5**

STF1.5-2.5

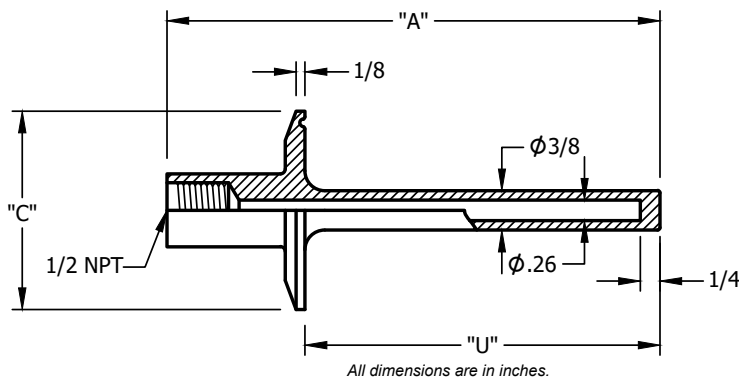

Tri-Clamp® Size	"A" Stem Length	"U" Dimension	"C" Dimension	Code
1-1/2"	2-1/2"	1-5/8"	2"	STF1.5-2.5
	4"	2-1/2"		STF1.5-4
	6"	4-1/2"		STF1.5-6
	9"	7-1/2"		STF1.5-9
2"	2-1/2"	1-5/8"	2.5"	STF2-2.5
	4"	2-1/2"		STF2-4
	6"	4-1/2"		STF2-6
	9"	7-1/2"		STF2-9
2-1/2"	2-1/2"	1-5/8"	3.1"	STF2.5-2.5
	4"	2-1/2"		STF2.5-4
	6"	4-1/2"		STF2.5-6
	9"	7-1/2"		STF2.5-9
3"	2-1/2"	1-5/8"	3.6"	STF3-2.5
	4"	2-1/2"		STF3-4
	6"	4-1/2"		STF3-6
	9"	7-1/2"		STF3-9

BIMETAL OPTION CODES

Part #	Description	Industrial AO, LO, MO, JO, XO, YO, VO	Process AA, RR, CC, CN, BB, SS, XR, XX, YY, YN, VR, VV, LL, MM, JJ	Small Dial OEM QQ, GG, HH	Digital DT, DTR, BT	Dual Mode Thermometer DMT
CASE FILL OPTIONS						
-SF	Silicone Filled Case	N/A	✓	N/A	N/A	✓
LENS OPTIONS						
-PC	Acrylic Window	N/A	✓	✓	N/A	✓
-PY	Polycarbonate Window	N/A	✓	✓	STD	✓
-TG	Tempered Safety Glass Lens	N/A	✓	N/A	N/A	✓
-SG	Laminated Safety Glass Lens	N/A	✓	N/A	N/A	✓
-GL	Plain Glass	N/A	STD	STD	✓	STD
STEM OPTIONS						
-PS	Pointed Tip	N/A	✓	✓	✓	N/A
-SS	316 Stainless Steel Stem	N/A	✓	✓	✓	✓
-F5	5/16" Diameter Stem (Not Available with 316SS Stem)	N/A	✓	✓	✓	N/A
-S3	3/8" Diameter Stem	N/A	✓	✓	✓	✓
-TF	Teflon Coating (Stem Only)	N/A	✓	✓	✓	✓
DIAL OPTIONS						
-CL	Custom Logo Dial	N/A	✓	✓	✓	✓
-HV	Hi-Vis Dial	N/A	✓	MQ	N/A	✓
-CB	Color Band	N/A	✓	MQ	N/A	✓
-PI	Color Pie	N/A	✓	MQ	N/A	✓
-WD	White Dial (Standard Ranges Only)	N/A	✓	✓	✓	✓
-MM	Min/Max Pointer	N/A	✓	N/A	N/A	✓
NL	No Logo	N/A	✓	✓	✓	✓
TAG OPTION						
-TS	Stainless Steel Tag (1-10 Characters)	✓	✓	✓	✓	✓
-TP	Paper Tag	✓	✓	✓	✓	✓
-TM	Stainless Steel Tag (11-80 Characters)	✓	✓	✓	✓	✓
CERTIFICATION OPTIONS						
-R1	1pt. Calibration Certification (Reotemp Chooses the Point)	N/A	✓	✓	✓	✓
-R3	3 pt. Calibration Certification (Reotemp Chooses the Points)	N/A	✓	✓	✓	✓
-C1	1 pt. Calibration Certification (Customer Chooses the Point)	N/A	✓	✓	✓	✓
-C3	3 pt. Calibration Certification (Customer Chooses the Points)	N/A	✓	✓	✓	✓
-CS	NIST Calibration Sticker (No Logged Points)	N/A	✓	✓	✓	✓
-CC	Certificate of Conformance	N/A	✓	✓	✓	✓
OTHER						
-3H	316 Stainless Steel Head & Bezel	N/A	✓	N/A	STD	✓
-HT	Heat Transfer Compound	✓	✓	✓	✓	✓
-CH	Spring Handle (T-27)	N/A	✓	✓	✓	N/A
-AS	Allows Bimet to Fit 1-1/4-18 xxowell	N/A	✓	✓	✓	✓

THERMOMETERS

✓	Indicates that the option is available with the model.
STD	Indicates standard options with no additional cost.

N/A	Indicates the option is not available with this model.
MQ	Minimum order quantity applies.

BIMETAL RANGE CODES

FAHRENHEIT RANGES		
Code	°F Range	Div.
F03	-100/100	2
F05	-100/200	2
F07	-80/120	2
F11	-70/150	2
F19	-50/300	5
F21 [†]	-40/120	2
F23	-40/160	2
F25	-40/180	2
F26	-40/200	2
F27 [‡]	-40/70	1
F31 [†]	-20/120	2
F33	-20/425	5
F35 [‡]	0/100	1
F37 [†]	0/140	2
F39 [†]	0/150	1
F43	0/200	2
F45	0/220	2
F47	0/250	2
F49	0/300	2
F50	0/500	5
F51	0/600	10
F53	20/240	2
F55 [‡]	25/125	1
F57 [‡]	30/130	1
F63	50/300	2
F65	50/400	5
F67	50/500	5
F69	50/550	5
F71	50/650	10
F73	50/750	10
F78	100/600	5
F79	100/800	10
F81	150/750	10
F82	200/700	20
F83	200/300	2
F84	100/900	5
F85	200/1000	10
F89	250/600	5
F91	300/400	2

CELSIUS RANGES		
Code	°C Range	Div.
C01	-80/220	2
C03	-70/70	2
C06	-70/30	1
C07	-50/50	1
C08	-60/120	2
C09 [‡]	-50/0	1
C15	-50/100	2
C17	-50/200	2
C19	-40/160	2
C20	-60/300	5
C23	-40/70	1
C24	-40/350	5
C27 [‡]	-30/30	1
C31 [†]	-20/40	1
C32	-20/60	
C33	-20/220	2
C34	-20/320	5
C35 [‡]	0/30	.5
C37 [‡]	0/60	1
C38 [†]	0/80	
C43	0/100	1
C47	-20/120	2
C53	-10/110	1
C55 [‡]	0/50	.5
C56	0/120	1
C59	0/150	1
C60	50/150	
C61	0/160	2
C63	10/150	2
C65	0/200	2
C67	0/250	2
C69	0/300	2
C71	0/300	5
C73	0/400	5
C74	0/450	5
C75	0/500	5
C79	50/450	5
C81	50/400	5
C85	100/500	5
C87	100/550	5

DUAL RANGES	
Code	°F & °C Range
D01	-150/400 & 100/200
D03	-100/100 & -70/40
D07	-80/120 & -60/50
D15	-50/210 & -50/100
D19	-50/300 & -40/160
D23	-40/160 & -40/70
D37 [†]	0/140 & -15/60
D39 [†]	0/150 & -20/65
D41 [†]	0/160 & -15/70
D43	0/200 & -10/90
D45	0/220 & -10/100
D47	0/250 & -20/120
D49	0/300 & -10/150
D53	20/240 & -10/115
D55 [‡]	25/125 & -5/50
D63	50/300 & 10/150
D65	50/400 & 10/200
D67	50/500 & 10/260
D69	50/550 & 10/290
D77	100/450 & 40/230
D79	100/800 & 40/400
D81	150/750 & 70/400
D85	200/1000 & 100/500
D87	200/1000 & 100/550

‡ Minimum stem length is 4".

† For 2.5" stem, all bottom connect and all-angle models require adapter P/N AD22S.