

MODEL W FIELD MOUNTED HART TEMPERATURE TRANSMITTER

The Reotemp Model W Explosion Proof Field Mounted HART Temperature Transmitter features a local display, HART compatibility, and a 4-20mA output. The field mounted transmitter is available as a complete RTD or thermocouple assembly customized to your process.



Made in USA



FEATURES / BENEFITS

- RTD or TC Input, Analog Output
- High Definition Local Operator Interface (LOI) with 3 Optical Buttons
- Selectable Red or White Backlight
- Ex d Explosion Proof / Flame Proof Aluminum Head
- HART 7 Functionality with HART 5 Compatibility

HIGH DEFINITION DISPLAY

- 0, 90, 180, & 270 degree position adjustments
- Monitoring, programming and diagnostics view
- Extensive diagnostics with flashing red or white backlight

LOCAL OPERATOR INTERFACE (LOI)

- 3 optical buttons; up, down and enter
- Dynamically adaptive to wear or accumulation of dirt
- Immune to interference from ambient light sources
- Useable with or without gloves

CONFIGURATION

- From the LOI through guided menu
- PReset and HART modem
- HHC, DCS or AMS via HART

MOUNTING / INSTALLATION

- For installation in zone 0, 1, 2 and zone 20, 21, 22 and in Class 1, Division 1 and 2 applications
- Hardware assessed for use in SIL 2 applications
- Mounting on 1.5"-2" pipe bracket or on wall / bulkhead

APPLICATION

- Linearized temperature measurement with TC and RTD sensors e.g. Pt100 and Ni100
- HART communication and 4...20 mA analog PV output for individual, difference or average temperature measurement of up to two RTD or TC input sensors
- Up to 63 transmitters (HART 7) can be connected in a multidrop communication setup

TECHNICAL CHARACTERISTICS

- NAMUR NE43 and NE89
- HART protocol revision can be changed by user configuration to either HART 5 or HART 7 protocol

RTD to 4-20 mA

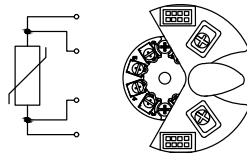

TC to 4-20 mA

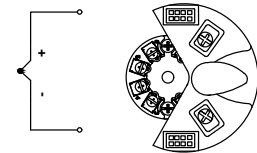

Difference or Average RTD, TC or mV

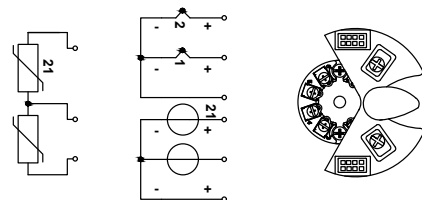

2-wire Output and HART

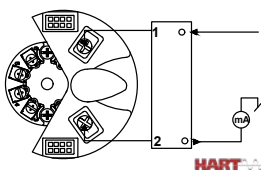

Ex ia: 10-30 VDC (12-30 VDC with backlight)
Other: 10-35 VDC (12-35 VDC with backlight)

4-20 mA



MODEL W FIELD MOUNTED HART TEMPERATURE TRANSMITTER

SPECIFICATIONS

Environmental Conditions	
Operating Temperature	-40°C to +85°C
Storage Temperature	-40°C to +85°C
Calibration Temperature	20...28°C
Relative humidity	0...100% RH (condensing)
Protection degree	IP54 / IP66 / IP68 / type 4X
Mechanical Specifications	
Dimensions	Ø 110 mm
Dimensions (HxWxD), aluminum	109.3 x 145 x 126 mm
Weight approx.	1.3kg
Wire size	0.13 x 1.5 mm ² / AWG 26...16 stranded wire
Screw terminal torque	0.4 Nm
Vibration	IEC 60068-2-6
2...25 Hz	±1.6 g
25...100 Hz	±4 g
Number of digits	5
Backlight	Selectable ON/OFF
Backlight color	Selectable white or red
Common Specifications	
Supply voltage, DC: Ex ia, intrinsically safe	10 (12 - with backlight)...30 VDC
Supply voltage, DC: Other	10 (12 - with backlight)...35 VDC
Isolation voltage, test / working	1.5 kVAC / 50 VAC
Response time (programmable)	1...60 s
Signal / noise ratio	> 60 dB
Programming	HART
Start-up time, transmitter to display	Max. 5 s
Long-term stability, better than	±0.1% of span / year
Transmitter Accuracy	Better than 0.05% of selected range
Signal dynamics, input	22 bit
Signal dynamics, output.	16 bit
EMC immunity influence	< ±0.1% of span
Extended EMC immunity: NAMUR NE21, A criterion, burst	< ±1% of span
Max. offset.	50% of selected max. value

Input Specifications	
RTD type	Pt50/100/200/500/1000; Ni50/100/120/1000
Cable resistance per wire	5 Ω (up to 50 Ω per wire is possible with reduced measurement accuracy)
Sensor current	Nom. 0.2 mA
Thermocouple type	B, E, J, K, N, R, S, T
Cold junction compensation (CJC)	Constant, internal or external via a Pt100 or Ni100 sensor
Output Specifications	
Signal range	4...20 mA
Min. signal range	16 mA
Load (@ current output)	≤ (Vsupply - 10) / 0.023 [Ω]
Load resistance, with backlight	≤ (Vsupply - 12) / 0.023 [Ω]
Sensor error indication	Programmable 3.5...23 mA
NAMUR NE43 Upscale/Downscale	23 mA / 3.5 mA
Updating time	440 ms
HART protocol revisions	HART 7 and HART 5
Observed Authority Requirements	
EMC	2014/30/EU
EAC	TR-CU 020/2011
Approvals	
EU RO Mutual Recognition Type Approval	MRA0000009
ATEX 2014/34/EU	DEKRA 15 ATEX 0058 X
IECEX	IECEX DEK 15.0039 X
FM	FM16US0009X / FM16CA0010X
CSA	70024231
EAC Ex TR-CU 012/2011	RU C-DK.GB08.V.01316
INMETRO	DEKRA 15.0014 X
NEPSI	GYJ15.1336X, GYJ15.1337X and GYJ15.1338X
SIL	Hardware assessed for use in SIL applications

MODEL W FIELD MOUNTED HART TEMPERATURE TRANSMITTER (DIRECT MOUNT RTD)

W

BUILD YOUR MODEL W (DIRECT MOUNT):
Choose options to build a part number. For example: **WHY1TPX1256X-TS**

H

Y

HEAD STYLE		HEAD OPTIONS	TRANSMITTER
	W Explosion Proof Field Mounted HART Direct Mount Transmitter with Display	H = 1/2" Conduit	Y = 4-20mA 2-wire HART Transmitter

1T

PX

THREADED CONNECTIONS RTD SENSOR

Use a spring loaded connection with a thermowell. Use a welded connection when the stem goes directly into the process medium. All threaded connections have 316 stainless steel fittings.

Threaded Connections

- 1T** = Spring-loaded 316SS Hex Bushing
- 4T** = 5" Nominal Spring Loaded Nipple-Union-Nipple 316SS
- 2T** = 2.5" Spring Loaded Nipple 316SS
- 7T** = Spring Loaded Explosion Proof Bushing 316SS
- 5T** = Nipple-Union-Nipple Spring Loaded Explosion Proof Bushing, Explosion Proof Union

Other Nipple-Union-Nipple (N-U-N)

- 4T3** = 3" Nominal Spring Loaded N-U-N
- 4T4** = 4" Nominal Spring Loaded N-U-N
- 4T6** = 6" Nominal Spring Loaded N-U-N
- 4T7** = 7" Nominal Spring Loaded N-U-N

Nipples

- 2T3** = 3" Spring Loaded Nipple
- 2T4** = 4" Spring Loaded Nipple
- 2T5** = 5" Spring Loaded Nipple
- 2T6** = 6" Spring Loaded Nipple
- 2T7** = 7" Spring Loaded Nipple
- 2T8** = 8" Spring Loaded Nipple

Welded Fittings

- 1F** = Welded Hex Bushing 316SS
- 4F** = Nipple-Union-Nipple Welded 316SS
- 6F** = Stainless Steel Bushing, 1/2" NPT, No Process Threads

Special Fittings

- 8T** = Spring Loaded Terminal Block, No Fitting 1/2" NPT Female Head Opening

Welded Fittings with Compression Fitting Loose on Stem

- 6FT** = SS Welded Bushing with 1/4" NPT Comp Fitting "Set Once" Loose On Stem
- 6FU** = SS Welded Bushing with 1/2" NPT Comp Fitting "Set Once" Loose On Stem
- 6FV** = SS Welded Bushing with 1/8" NPT Comp Fitting "Set Once" Loose On Stem

Type	Code	Material/Class	Ω at 0°C	Accuracy at 0°C(Ω)
Standard DIN B Platinum 100Ω	PX*	Pt/385/B	100Ω	± 0.12%
Platinum 100Ω with Other Accuracies	PA*	Pt/385/A	100Ω	± 0.06%
	PD*	Pt/385/A3	100Ω	± 0.03%
	PE*	Pt/385/A5 (1/10 B)	100Ω	± 0.01%
Other RTDs	PK*	Pt/385/B	1000Ω	± 0.12%
	PH*	Pt/385/A	1000Ω	± 0.06%
	PM	Pt/385/B	500Ω	± 0.12%
	NI	Nickel/6725	120Ω	± 0.50%

*Available in Reotemp Extended temperature RTDs.

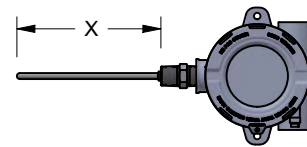

TRANSMITTERS

1

25

6

X

-TS

TEMPERATURE RANGE	STEM DIAMETER	STEM LENGTH	NUMBER OF RTDs/LEADS	OPTIONS
-------------------	---------------	-------------	----------------------	---------

- 1** = -328°F/400°F (Standard)
- 2** = Extended Range -328°F/1100°F (Only Available on PX, PA, PD, PH, PE, or PK RTDs)

- 25** = 0.250"
- 12** = 0.125"
- 18** = 0.188"
- 37** = 0.375"

? = Stem Length in Inches

- X** = Single 3-wire
- XX** = Duplex 3-wire
- Y** = Single 4-wire
- YY** = Duplex 4-wire
- W** = Single 2-wire
- WW** = Duplex 2-wire

- TS** = Tag, Stainless
- R1** = One Point Calibration Cert (Reotemp Chooses Points)
- R3** = Three Point Calibration Cert (Reotemp Chooses Points)

Additional Options Available

MODEL W FIELD MOUNTED HART TEMPERATURE TRANSMITTER (REMOTE MOUNT RTD)

BUILD YOUR MODEL W (REMOTE MOUNT): Choose options on this page to begin the remote mount RTD stem part number. Then, add the stem part number to lead wire part number generated on page 157. For example: APX1256X-LR3A36T2RHWYA-TS

A

STYLE

□

STEM OPTIONS (OPTIONAL)

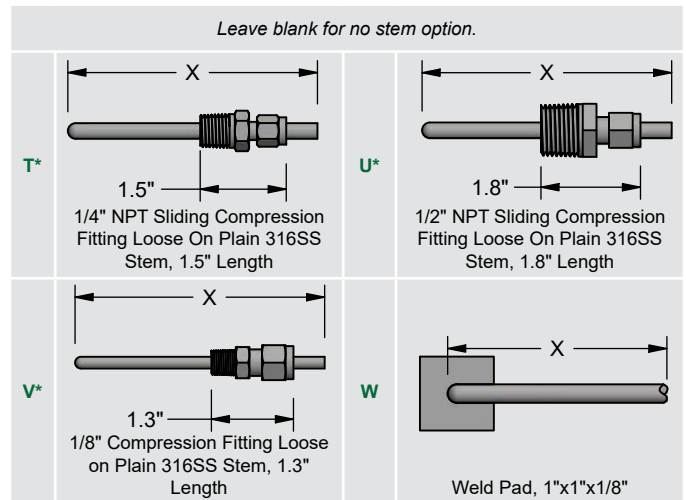
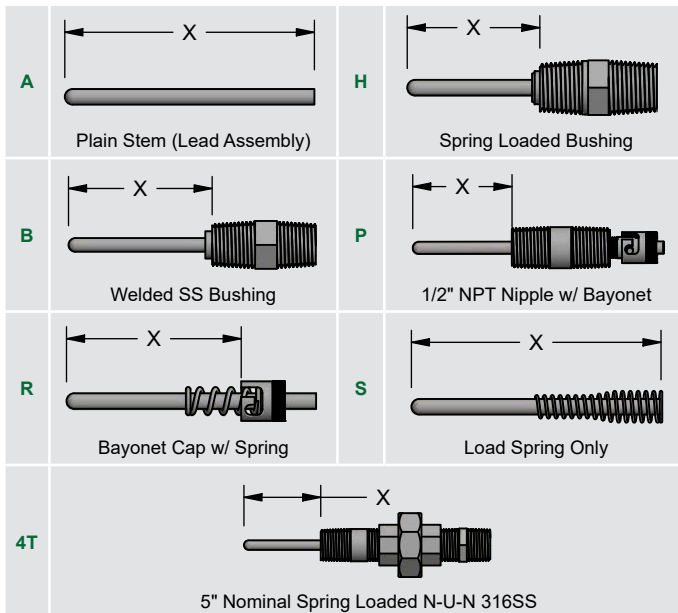

*These fittings decrease usable stem length by the length of the fitting as pictured above. Add the fitting size to the required stem length or your stem may be short.

PX

RTD SENSOR

1

TEMPERATURE RANGE

25

STEM DIAMETER

6

STEM LENGTH "X"

X

NUMBER OF RTDs/LEADS

Type	Code	Material/Class	Ω at 0°C	Accuracy at 0°C(Ω)
Standard DIN B Platinum 100 Ω	PX*	Pt/385/B	100 Ω	$\pm 0.12\%$
Platinum 100 Ω with Other Accuracies	PA*	Pt/385/A	100 Ω	$\pm 0.06\%$
	PD*	Pt/385/A3	100 Ω	$\pm 0.03\%$
	PE*	Pt/385/A5 (1/10 B)	100 Ω	$\pm 0.01\%$
Other RTDs	PK*	Pt/385/B	1000 Ω	$\pm 0.12\%$
	PH*	Pt/385/A	1000 Ω	$\pm 0.06\%$
	PM	Pt/385/B	500 Ω	$\pm 0.12\%$
	NI	Nickel/6725	120 Ω	$\pm 0.50\%$

*Available in Reotemp Extended temperature RTDs.

1 = -328°F/400°F (Standard)
2 = Extended Range -328°F/1100°F (Only Available on PX, PA, PE, PK, PD, or PH RTDs)

25 = 0.250"
12 = 0.125"
18 = 0.188"
37 = 0.375"

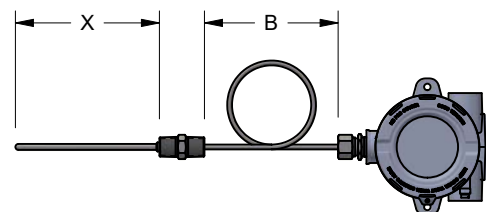

? = Stem Length in Inches

X = Single 3-wire
XX = Duplex 3-wire
Y = Single 4-wire
YY = Duplex 4-wire
W = Single 2-wire
WW = Duplex 2-wire

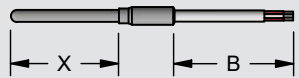
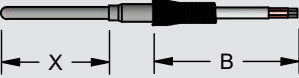
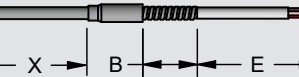
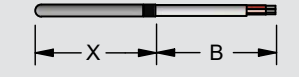
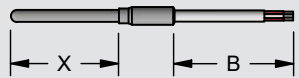
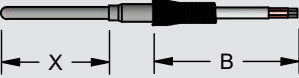
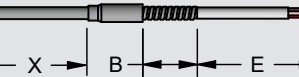
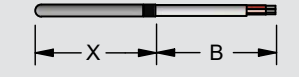
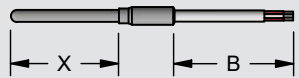
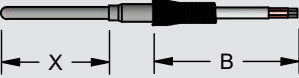
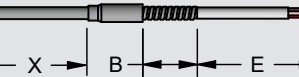
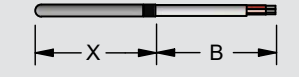

MODEL W FIELD MOUNTED HART TEMPERATURE TRANSMITTER (REMOTE MOUNT RTD)

-L 	R 	3 	A 												
LEAD WIRE	SENSOR TYPE	NUMBER OF LEADS	TRANSITION TYPE												
-L = Lead Wire	R = RTD	2 = 2-Wire RTD 3 = 3-Wire RTD 4 = 4-Wire RTD or Duplex 2-Wire RTD 6 = Duplex 3-Wire RTD 8 = Duplex 4-Wire RTD	<table border="1"> <tr> <td style="text-align: center;">P</td> <td></td> <td style="text-align: center;">Plain (Standard)</td> </tr> <tr> <td style="text-align: center;">S</td> <td></td> <td style="text-align: center;">Spring</td> </tr> <tr> <td style="text-align: center;">A</td> <td></td> <td style="text-align: center;">Armor</td> </tr> <tr> <td style="text-align: center;">L</td> <td></td> <td style="text-align: center;">Same Size</td> </tr> </table>	P		Plain (Standard)	S		Spring	A		Armor	L		Same Size
P		Plain (Standard)													
S		Spring													
A		Armor													
L		Same Size													

36 	T2 	RHWY 				
WIRE OR ARMOR LENGTH "B"	INSULATION & CONDUCTOR	WIRE TERMINATION				
?? = "B" Length in Inches	T2 = Teflon with 24 AWG Stranded Wire T3 = Teflon with 20 AWG Stranded Wire A2 = Teflon with 24 AWG Stranded Wire, Mylar Shield & Drain F2 = Fiberglass with 24 AWG Stranded Wire	<table border="1"> <tr> <td style="text-align: center;"></td> <td style="text-align: center;">RHWY</td> <td style="text-align: center;">Cord Grip with Explosion Proof Field Mounted HART Transmitter with Display, 3/4" Conduit, 4-20mA 2-wire HART Transmitter</td> <td style="text-align: center;">FM, CSA, ATEX, IEC, IECex</td> </tr> </table>		RHWY	Cord Grip with Explosion Proof Field Mounted HART Transmitter with Display, 3/4" Conduit, 4-20mA 2-wire HART Transmitter	FM, CSA, ATEX, IEC, IECex
	RHWY	Cord Grip with Explosion Proof Field Mounted HART Transmitter with Display, 3/4" Conduit, 4-20mA 2-wire HART Transmitter	FM, CSA, ATEX, IEC, IECex			

A 	-TS
WIRE PROTECTION (OPTIONAL)	OPTIONS
= Leave Blank for No Armor Protection A = Stainless Steel Armor P = PVC Coated Stainless Steel Armor T = Teflon Coated Stainless Steel Armor O = Stainless Steel Overbraid	-TS = Tag, Stainless -R1 = One Point Calibration Cert (Reotemp Chooses Points) -R3 = Three Point Calibration Cert (Reotemp Chooses Points) Additional Options Available

TRANSMITTERS

MODEL W FIELD MOUNTED HART TEMPERATURE TRANSMITTER (DIRECT MOUNT THERMOCOUPLE)

W

BUILD YOUR MODEL W (DIRECT MOUNT TC): Choose options to build a part number. For example: **WHY1TM25K1SG6-TS**

H

Y

HEAD STYLE		HEAD OPTIONS	TRANSMITTER
	W Explosion Proof Field Mounted HART Direct Mount Transmitter with Display	H = 1/2" Conduit	Y = 4-20mA 2-wire HART Transmitter

1T

M

25

K

THREADED CONNECTIONS	METAL SHEATH	SHEATH DIAMETER	THERMOCOUPLE TYPE
----------------------	--------------	-----------------	-------------------

Use a spring loaded connection with a thermowell. Use a welded connection when the stem goes directly into the process medium. All threaded connections have 316 stainless steel fittings.

Threaded Connections

- 1T** = Spring-loaded 316SS Hex Bushing
- 4T** = 5" Nominal Spring Loaded Nipple-Union-Nipple 316SS
- 2T** = 2.5" Spring Loaded Nipple 316SS
- 7T** = Spring Loaded Explosion Proof Bushing 316SS
- 5T** = Nipple-Union-Nipple Spring Loaded Explosion Proof Bushing, Explosion Proof Union

Welded Fittings

- 1F** = Welded Hex Bushing 316SS
- 4F** = Nipple-Union-Nipple Welded 316SS
- 6F** = Stainless Steel Bushing, 1/2" NPT, No Process Threads

Welded Fittings with Compression Fitting Loose on Stem

- 6FT** = SS Welded Bushing with 1/4" NPT Comp Fitting "Set Once" Loose On Stem
- 6FU** = SS Welded Bushing with 1/2" NPT Comp Fitting "Set Once" Loose On Stem
- 6FV** = SS Welded Bushing with 1/8" NPT Comp Fitting "Set Once" Loose On Stem

Other Nipple-Union-Nipple (N-U-N)

- 4T3** = 3" Nominal Spring Loaded N-U-N
- 4T4** = 4" Nominal Spring Loaded N-U-N
- 4T6** = 6" Nominal Spring Loaded N-U-N
- 4T7** = 7" Nominal Spring Loaded N-U-N

Nipples

- 2T3** = 3" Spring Loaded Nipple
- 2T4** = 4" Spring Loaded Nipple
- 2T5** = 5" Spring Loaded Nipple
- 2T6** = 6" Spring Loaded Nipple
- 2T7** = 7" Spring Loaded Nipple
- 2T8** = 8" Spring Loaded Nipple

Special Fittings



- 8T** = Spring Loaded Terminal Block, No Fitting 1/2" NPT Female Head Opening

M = Metal Sheathed Thermocouple

- 06** = 0.062 in
- 12** = 0.125 in
- 18** = 0.188 in
- 25** = 0.250 in
- 37** = 0.375 in

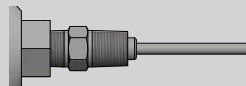
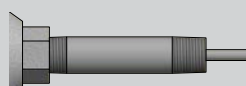
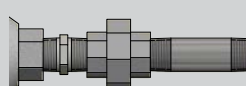
- J** = Type J
- K** = Type K
- E** = Type E
- T** = Type T
- JS** = Type J Special Limits of Error
- KS** = Type K Special Limits of Error
- ES** = Type E Special Limits of Error
- TS** = Type T Special Limits of Error

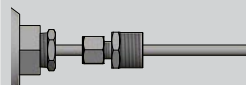
Connection Types		
1T, 7T, 1F	Hex Bushing	
2T	Pipe Nipple	
4T3, 4T, 5T, 4F, etc.	Nipple-Union-Nipple (N-U-N)	

Connection Types		
6FT, 6FU, 6FV	Compression Fitting	
6F	No Process Threads	

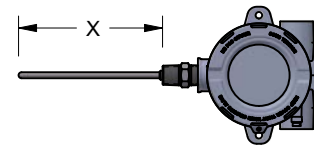

1

S

G

6

-TS

SHEATH MATERIAL	NUMBER OF ELEMENTS	TYPE OF JUNCTION	STEM LENGTH "X"	OPTIONS
-----------------	--------------------	------------------	-----------------	---------

- 1** = 316 Stainless Steel
- 2** = 310 Stainless Steel
- 3** = 304 Stainless Steel
- 5** = Inconel 600

- S** = Single Element Assembly
- D** = Dual Element Assembly

- G** = Grounded Elements
- E** = Exposed Elements
- U** = Ungrounded Elements
- UU** = Ungrounded Uncommon Elements

Stem length measured from bottom of threads to stem tip.
??? = Stem length in inches.

- TS** = Tag, Stainless
- R1** = One Point Calibration Cert (Reotemp Chooses Points)
- R3** = Three Point Calibration Cert (Reotemp Chooses Points)

Additional Options Available

MODEL W FIELD MOUNTED HART TEMPERATURE TRANSMITTER (REMOTE MOUNT THERMOCOUPLE)

BUILD YOUR MODEL W REMOTE MOUNT THERMOCOUPLE: Choose options to build a part number. For example: **ATM12J1SG6-LJ2S36T2RHWHYA-TS**

STYLE		STEM OPTIONS (OPTIONAL)	
A	 Plain Stem (Lead Assembly)	H	 Spring Loaded Bushing
B	 Welded SS Bushing	P	 1/2" NPT Nipple w/ Bayonet
R	 Bayonet Cap w/ Spring	S	 Load Spring Only
4T	 5" Nominal Spring Loaded N-U-N 316SS		
<i>Leave blank for no stem option.</i>			
T*	 1.5" 1/4" NPT Sliding Compression Fitting Loose On Plain 316SS Stem, 1.5" Length	U*	 1.8" 1/2" NPT Sliding Compression Fitting Loose On Plain 316SS Stem, 1.8" Length
V*	 1.3" 1/8" Compression Fitting Loose on Plain 316SS Stem, 1.3" Length	W	 Weld Pad, 1"x1"x1/8"

*These fittings decrease usable stem length by the length of the fitting as pictured above. Add the fitting size to the required stem length or your stem may be short.

M	12	J	1	S	G	6
METAL SHEATH	SHEATH DIAMETER	ANSI TYPE THERMOCOUPLE	TYPE OF SHEATH MATERIAL	NUMBER OF ELEMENTS	TYPE OF JUNCTION	STEM LENGTH "X"

M = Metal Sheathed Thermocouple

06 = 0.062 in
12 = 0.125 in
18 = 0.188 in
25 = 0.250 in
37 = 0.375 in

J = Type J
K = Type K
E = Type E
T = Type T
JS = Type J Special Limits of Error
KS = Type K Special Limits of Error
ES = Type E Special Limits of Error
TS = Type T Special Limits of Error

1 = 316 Stainless Steel
2 = 310 Stainless Steel
3 = 304 Stainless Steel
5 = Inconel 600

S = Single Element Assembly
D = Dual Element Assembly

G = Grounded
U = Ungrounded
E = Exposed
UU = Ungrounded Uncommon

?? = Stem Length in Inches

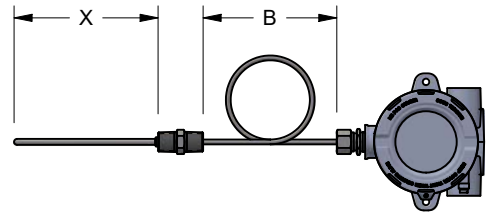

TRANSMITTERS



MODEL W FIELD MOUNTED HART TEMPERATURE TRANSMITTER (REMOTE MOUNT THERMOCOUPLE)

-L 	J 	2 	S
LEAD WIRE	THERMOCOUPLE TYPE	NUMBER OF LEADS	TRANSITION TYPE

-L = Lead Wire

J = Type J Thermocouple
 K = Type K Thermocouple
 E = Type E Thermocouple
 T = Type T Thermocouple

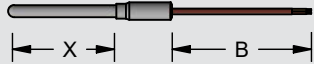
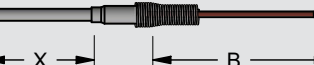
2 = Single Thermocouple
 4 = Duplex Thermocouple

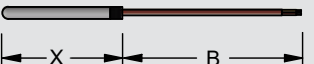
P		Plain Transition
S		Spring Transition
A		Armor Transition
L		Same Size

36 	T2 	RHWY
WIRE OR ARMOR LENGTH "B"	INSULATION /CONDUCTOR	WIRE TERMINATION

?? = Insert "B" Length in Inches

T1 = Teflon, 20 AWG, Solid
 F1 = Fiberglass, 20 AWG, Solid
 T2 = Teflon, 20 AWG, Stranded
 F2 = Fiberglass, 20 AWG, Stranded (J&K Only)
 P1 = PVC, 20 AWG, Solid



RHWY

Cord Grip with Explosion Proof Field Mounted HART Transmitter with Display, 1/2" Conduit, 4-20mA 2-wire HART Transmitter

FM, CSA, ATEX, IEC, IECEx

A 	-TS
WIRE PROTECTION (OPTIONAL)	OPTIONS

= Leave Blank for No Armor Protection
 A = Stainless Steel Armor
 P = PVC Coated Stainless Steel Armor
 T = Teflon Coated Stainless Steel Armor
 O = Stainless Steel Overbraid

-TS = Tag, Stainless
 -R1 = One Point Calibration Cert (Reotemp Chooses Points)
 -R3 = Three Point Calibration Cert (Reotemp Chooses Points)

Additional Options Available

HAZARDOUS LOCATION CERTIFIED THERMOCOUPLE & RTD OPTIONS

		Thermocouple	RTD
CERTIFICATION OPTIONS			
-R1	1 Point Calibration Certification, Reotemp Chooses	✓	✓
-R3	3 Point Calibration Certification, Reotemp Chooses	✓	✓
-C1	1 Point Calibration Certification, Customer Chooses	✓	✓
-C3	3 Point Calibration Certification, Customer Chooses	✓	✓
-CC	Certificate of Conformance	✓	✓
-CS	NIST Calibration Sticker (No Logged Points)	✓	✓
OTHER OPTIONS			
-VB	Hi-Vibration	N/A	✓
-AC	Hi-Accuracy	N/A	✓
-PS	Pointed Stem	✓	✓
-HT	Heat Transfer Compound (2 oz)	✓	✓
TAG OPTION			
-TS	Stainless Steel Tag (1-10 Characters)	✓	
-TM	Stainless Steel Tag (11-80 Characters)	✓	
-TP	Paper Tag	✓	
✓	Indicates that the option is available with this model.		
N/A	Indicates the option is not available with this model.		
STD	Indicates standard options with no additional cost.		