

# Deaerator Level Controls

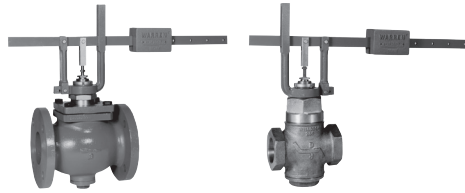

FLOAT CAGES



LEVER VALVES



OVERFLOW TRAPS



VACUUM BREAKERS

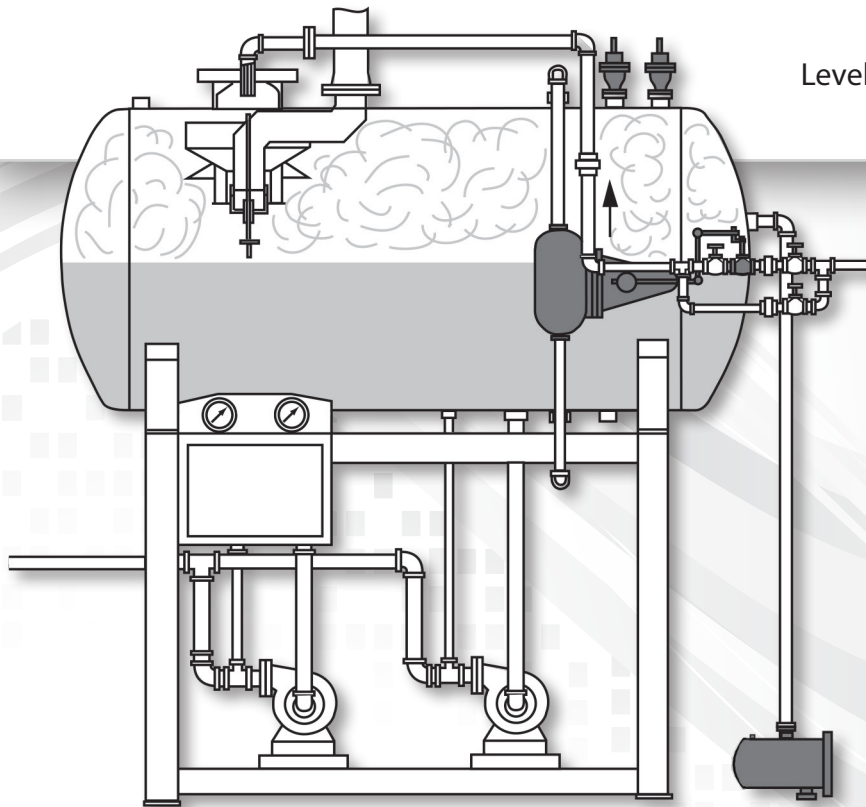

Level Controls\_PS\_Rev1\_1023

LEVEL CONTROLS PRODUCT SPEC

**WARREN CONTROLS**

2600 EMRICK BLVD • BETHLEHEM, PA 18020 • USA • 800-922-0085 • WWW.WARRENCONTROLS.COM  
DEPENDABLE, RUGGED, PRECISION CONTROL VALVES AND ACCESSORIES

## TABLE OF CONTENTS

377 Float Cage.....	3
326L Lever Valve / 322L Lever Valve .....	4-6
313 Overflow Trap .....	7
200 Vacuum Breaker .....	8-10
Terms & Conditions .....	11

## WARREN CONTROLS

### LEVEL CONTROLS AT WORK...

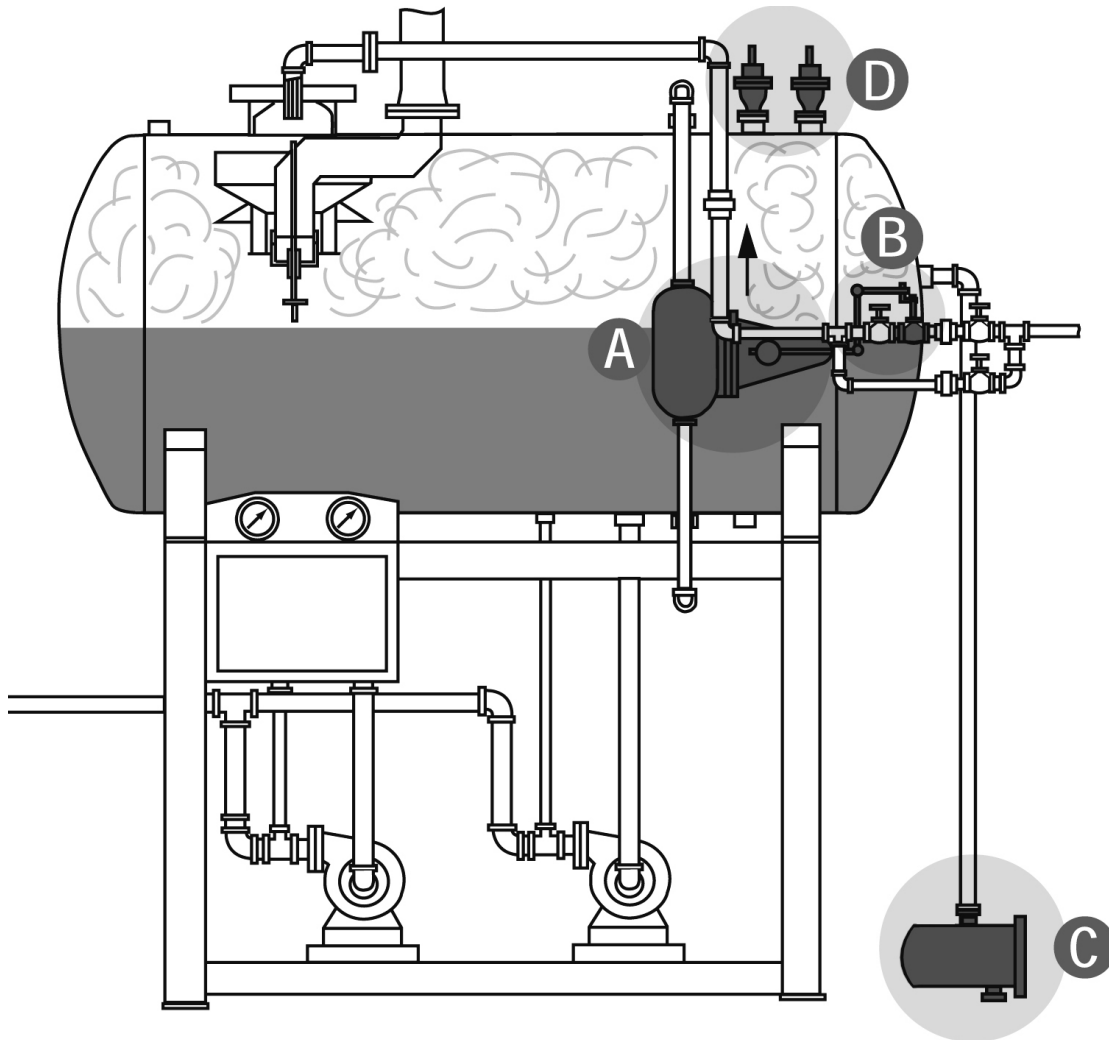

The following is a typical example of a tank filling/deaerator application using properly sized, selected, and maintained Warren Controls Level Controls. Demand for water reduces the liquid level in the tank. The [A] **377 Float Cage** opens the [B] **322L or 326L Lever Valve** to supply intake water to the tank. When the water reaches the desired level the float cage closes the lever valve to accurately maintain the liquid at the desired level. Deaerators, tanks with steam blankets, produce additional liquid as the steam condenses. The [C] **313 Overflow Trap** traps and relieves this condensate through its internal pilot without the steam blanket escaping. Overflow can occur if the water entering the tank exceeds its capacity. The 313 Overflow Trap relieves the overflow through its internal single seated main stage valve. Falling liquid levels and condensing steam can cause a vacuum that can damage the tank. The [D] **200 Vacuum Breaker** opens to admit outside air to relieve the vacuum in the tank. Warren Controls Level Controls are also used on boiler make-up water tanks and many other storage tank applications.

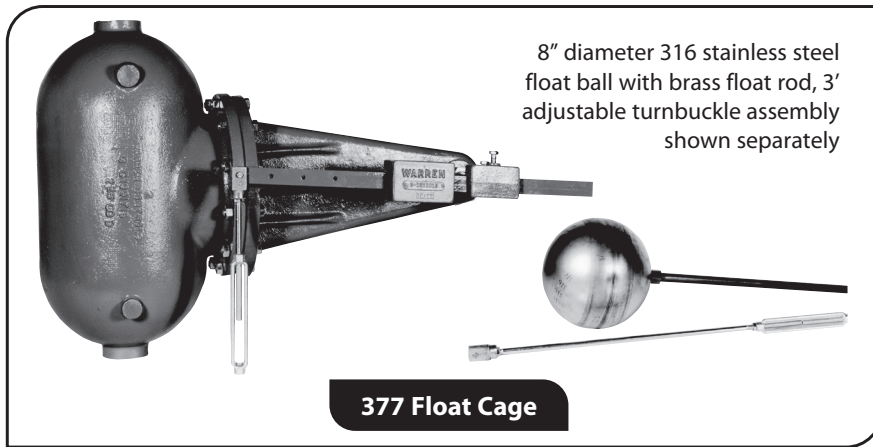

## ORDERING INFORMATION:

377	PART NUMBER
Standard 377	0377XXXXX000
377 with sight glass tapplings	0377XXXXX002
377 with sight glass assembly	0377XXXXX003
Extra Turnbuckle Sections	
2 Ft Section	B3100033
3 Ft Section	B3100034

## APPLICATION:

The 377 Float Cage opens a 322L or 326L Lever Valve to supply intake water to a tank. When the water reaches the desired level the Float Cage closes the Lever Valve to accurately maintain the liquid at the desired level. Buoyancy of its internal float ball provides the force to actuate the lever valve.

## FEATURES:

Cast iron body, 1-1/2" NPT connections, 316 stainless steel float ball, epr o-ring, steel lever and turnbuckle assembly.

- Lever and turnbuckle assembly are adjustable to ease installation and connection to lever valve.
- Standard turnbuckle is adjustable from 30 to 36 inches in length.
- Extra turnbuckle sections are available for a combined length up to 10 feet.
- Mounting bosses present on body can be provided with 1/2" NPT pipe tapplings for optional sight glass assembly.
- Optional sight glass assembly is available complete with brass ball check, shut-off valves, and drain valves.

## PRESSURE — TEMPERATURE RATINGS:

Body 125lb rated cast iron  
(175PSIG ... To 100F)

## APPROXIMATE SHIPPING WEIGHT:

190 lb

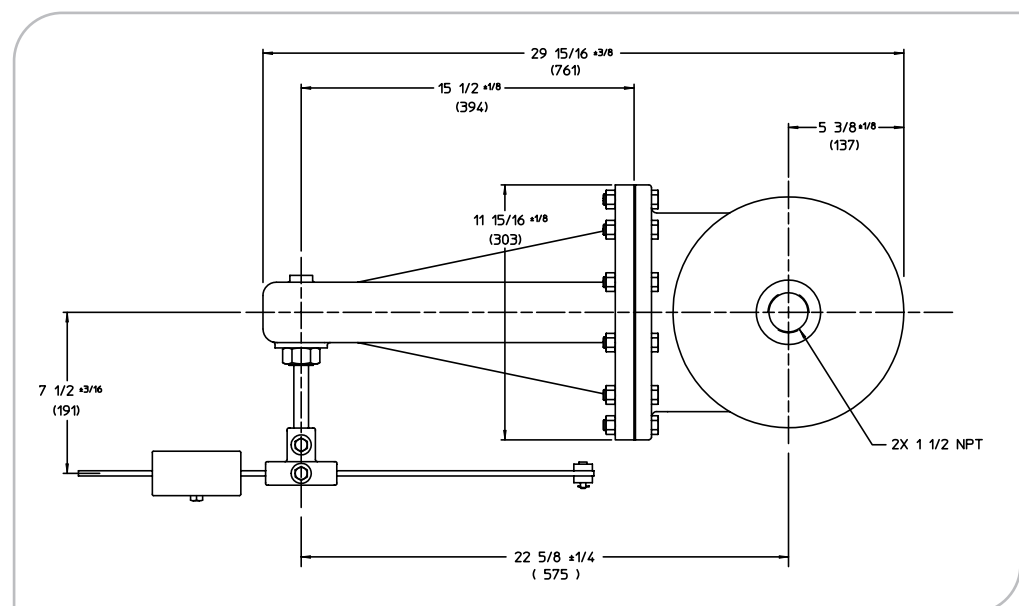
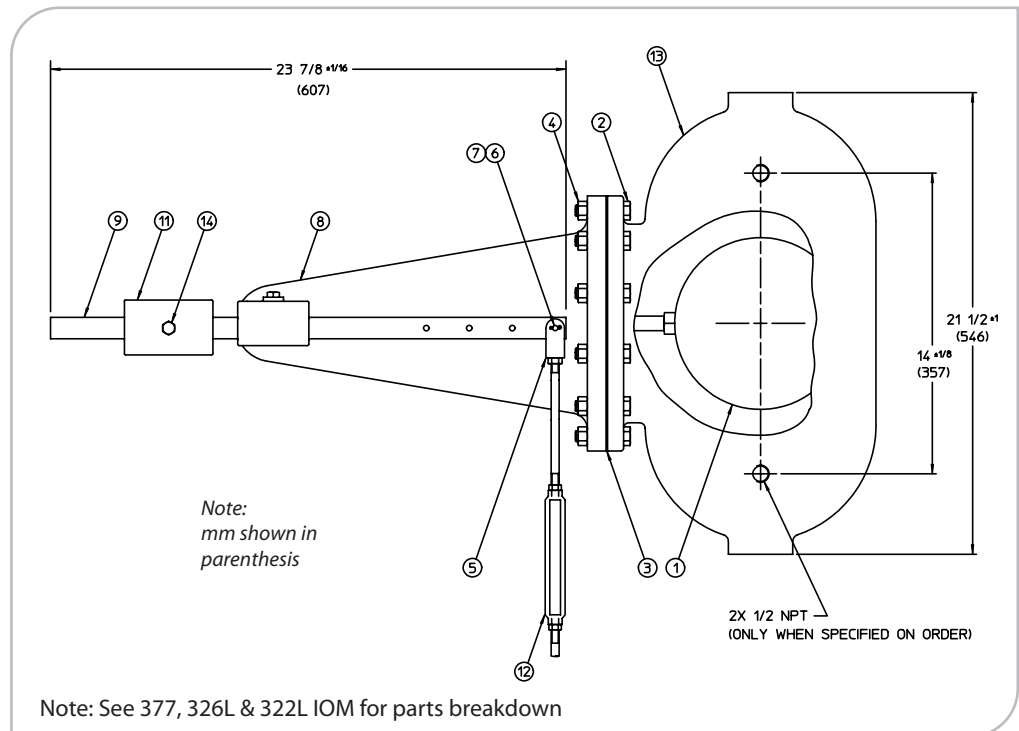

## 326L LEVER VALVE

### APPLICATION:

A 377 Float Cage opens the 326L Lever Valve to supply intake water to a tank. When the water reaches the desired level the Float Cage closes the Lever Valve to accurately maintain the liquid at the desired level. The 326L combines a balanced, pilot operated, single seated Type 26 globe valve with a rugged lever actuator.

### FEATURES:

- Bronze or stainless steel body, stainless steel trim, epr o-ring, cast iron lever actuator, and steel lever.
- EPDM lip packing is standard.
- TFE v-ring packing is optional, must be specified on order.
- Sizes 1/2" through 2" with NPT connections.
- Lever actuator is adjustable 360° around top of valve for ease of installation and connection to float cage.
- Lever actuator can be reversed from rising lever opens valve to rising lever closes valve.
- Cv's to 40
- Shut-off pressures to 100 PSI
- Nominal leakage rate 0.1% of rated capacity

*(EPDM lip packing is not suitable for use with oils, hydrocarbons, or acids.)*

*(TFE v-ring packing is not suitable for use with fluid temperatures below 60°F.)*



2" Bronze 326L

## 322L LEVER VALVE

### APPLICATION:

A 377 Float Cage opens the 322L Lever Valve to supply intake water to a tank. When the water reaches the desired level the Float Cage closes the Lever Valve to accurately maintain the liquid at the desired level. The 322L combines a double seated Type 22 globe valve with a rugged lever actuator.

### FEATURES:

- Cast iron body, bronze trim or stainless steel trim, cast iron lever actuator and steel lever.
- EPDM lip packing is standard.
- TFE v-ring packing is optional, must be specified on order.
- Sizes 1-1/2" and 2" with NPT connections
- 2-1/2" and 3" with 125FLG
- Lever actuator is adjustable 360° around top of valve for ease of installation and connection to float cage.
- Lever actuator can be reversed from rising lever opens valve to rising lever closes valve.
- Cv's to 100
- Shut-off pressures to 100PSI
- Nominal leakage rate 0.5% of rated capacity

*(EPDM lip packing is not suitable for use with oils, hydrocarbons, or acids.)*

*(TFE v-ring packing is not suitable for use with fluid temperatures below 60°F.)*

### PRESSURE-TEMPERATURE:

Temp (F)	Bronze & Iron Thd	Iron 125 Flg	St Steel Thd
+32 to 100F	400 PSIG	175 PSIG	400 PSIG

- STANDARD
- OPTIONAL

### WHAT'S AVAILABLE

Features	326L			322L		
	Size (IN)			Size (IN)		
	1/2,3/4,1	1-1/4	1-1/2,2	1-1/2,2	2-1/2,3	
Trim Material	BRONZE					●
	ST STL	●	●	●	●	●
Body Material & End Connection	BRONZE THREADED (NPT)	●	●	●		
	IRON THREADED (NPT)				●	
	ST STL THREADED (NPT)	●		●		
	IRON 125FLG					●
Packing	EPDM LIP	●	●	●	●	●
	TFE V-RING	○	○	○	○	○

# 326L LEVER VALVE / 322L LEVER VALVE

## SHUT-OFFS:

326L/322L	Maximum Shut-Off (PSID) Using 377 Float Cage							
	Valve Size (IN)							
Valve	1/2	3/4	1	1-1/4	1-1/2	2	2-1/2	3
326L	100	100	100	100	100	100	-	-
322L	-	-	-	-	100	100	80	60

## APPROXIMATE SHIPPING WEIGHTS:

326L/322L	Weights (LB)							
	Valve Size (IN)							
Valve	1/2	3/4	1	1-1/4	1-1/2	2	2-1/2	3
326L	24	24	25	32	32	37	-	-
322L	-	-	-	-	33	33	50	60

## FLOW COEFFICIENTS Cv:

326L/322L	Cv							
	Valve Size (IN)							
Valve	1/2	3/4	1	1-1/4	1-1/2	2	2-1/2	3
326L	6.9	7.7	10	19	25	40	-	-
322L	-	-	-	-	30	42	70	100

## FLOW CAPACITIES:

326L	GPM					
	Valve Size (IN)					
DP (PSI)	1/2	3/4	1	1-1/4	1-1/2	2
5	15	17	22	42	56	89
10	22	24	32	60	79	126
15	27	30	39	74	97	155
20	31	34	45	85	112	179
25	35	39	50	95	125	200
30	38	42	55	104	137	219
35	41	46	59	112	148	237
40	44	49	63	120	158	253
45	46	52	67	127	168	268
50	49	54	71	134	177	283

322L	GPM			
	Valve Size (IN)			
DP (PSI)	1-1/2	2	2-1/2	3
5	67	94	157	224
10	95	133	221	316
15	116	163	271	387
20	134	188	313	447
25	150	210	350	500
30	164	230	383	548
35	177	248	414	592
40	190	266	443	632
45	201	282	470	671
50	212	297	495	707

## ORDERING INFORMATION:

326L	Part Number		
	Description	Size	End Connection
BRONZE BODY WITH EQ% ST. STL.TRIM	1/2	NPT	VA2604AC-L000
	3/4	NPT	VA2605AC-L000
	1	NPT	VA2606AC-L000
	1-1/4	NPT	VA2607AC-L000
	1-1/2	NPT	VA2608AC-L000
	2	NPT	VA2609AC-L000
ST.STL.BODY WITH EQ% ST. STL.TRIM	1/2	NPT	VA2604EC-L000
	3/4	NPT	VA2605EC-L000
	1	NPT	VA2606EC-L000
	1-1/2	NPT	VA2608EC-L000
	2	NPT	VA2609EC-L000

322L	Part Number		
	Description	Size	End Connection
DOUBLE SEAT IRON BODY WITH EQ% ST. STL. TRIM	1-1/2	NPT	VA2208BC-L000
	2	NPT	VA2209BC-L000
DOUBLE SEAT IRON BODY WITH EQ% BRONZE TRIM	2-1/2	125 FLG	VA2210CA-L000
	3	125 FLG	VA2211CA-L000
DOUBLE SEAT IRON BODY WITH EQ% ST. STL.TRIM	2-1/2	125 FLG	VA2210CC-L000
	3	125 FLG	VA2211CC-L000

# 326L LEVER VALVE / 322L LEVER VALVE

## DIMENSIONS:

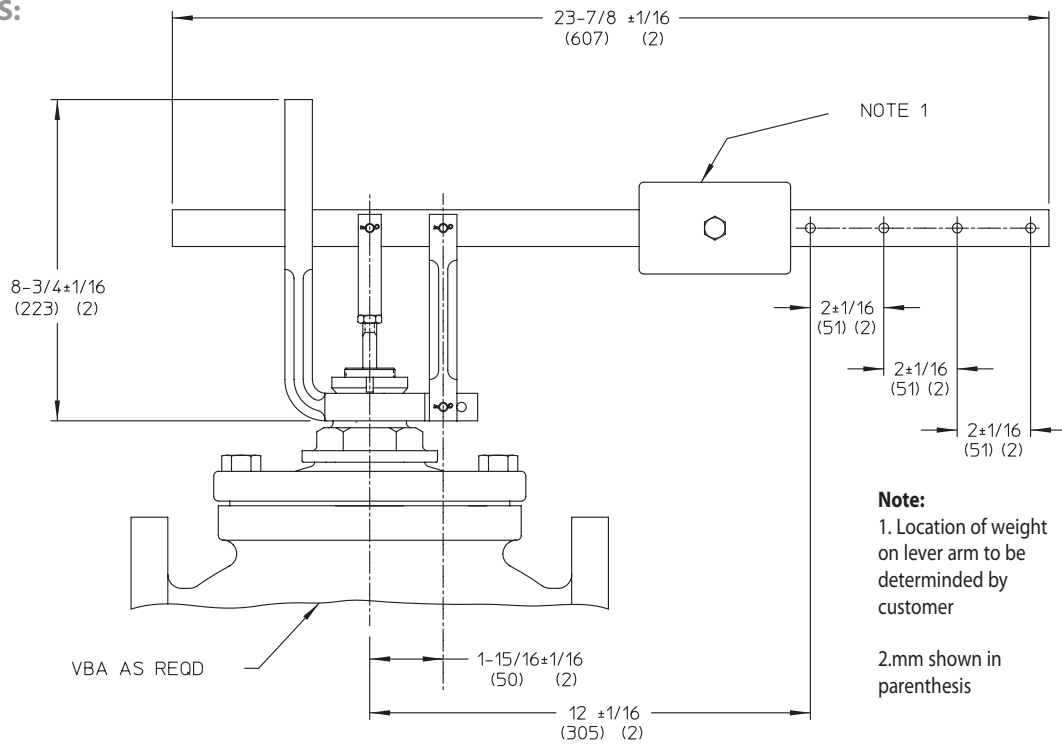

**Lever Actuator**

<b>326L</b>		Valve Size IN (mm)					
Dimension		1-1/4 -		2			
IN (mm)		1/2-1 (15-25)	1-1/2 (32-40)	1-1/2 (32-40)	2 (50)		
A	Bronze	4-7/8 (124)	5-3/4 (147)	5-3/4 (147)	6-1/2 (166)		
B	Bronze	2-5/8 (67)	3-1/8 (80)	3-1/8 (80)	3-7/16 (88)		
C	Bronze	3-13/16 (97)	4-3/16 (107)	4-3/16 (107)	4-3/4 (121)		
A	St. Steel	5 (127)	6-1/8 (156)	6-1/8 (156)	6-1/2 (166)		
B	St. Steel	2-13/16 (72)	3-3/8 (86)	3-3/8 (86)	3-11/16 (94)		
C	St. Steel	3-13/16 (97)	4-3/16 (107)	4-3/16 (107)	4-3/4 (121)		

<b>322L</b>		Valve Size IN (mm)							
Dimension		1-1/2 (40)		2 (50)		2-1/2 (65)		3 (80)	
IN (mm)		1-1/2 (40)	2 (50)	2 (50)	2-1/2 (65)	2-1/2 (65)	3 (80)	3 (80)	3 (80)
A		7-3/8 (188)	7-3/8 (188)	7-3/8 (188)	7-3/4 (197)	7-3/4 (197)	9 (229)	9 (229)	9 (229)
B		3-3/4 (96)	3-3/4 (96)	3-3/4 (96)	4 (102)	4 (102)	4-1/4 (108)	4-1/4 (108)	4-1/4 (108)
C		4-1/2 (115)	4-1/2 (115)	4-1/2 (115)	4-7/8 (124)	4-7/8 (124)	5-1/16 (129)	5-1/16 (129)	5-1/16 (129)

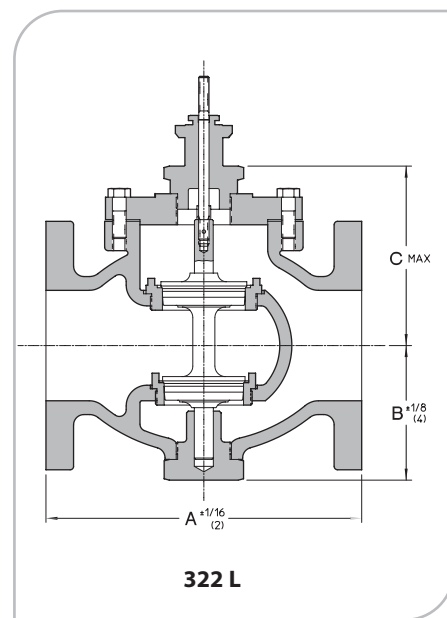
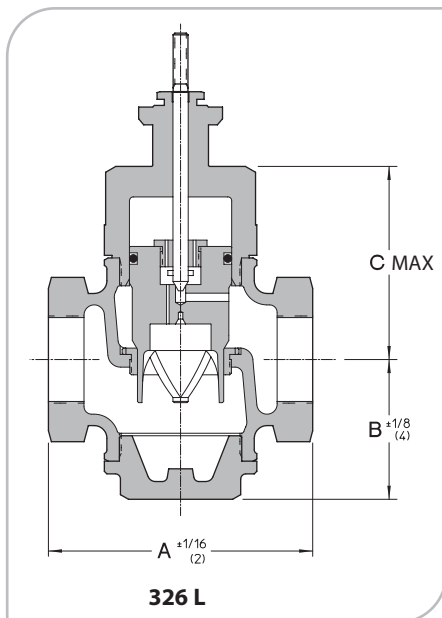

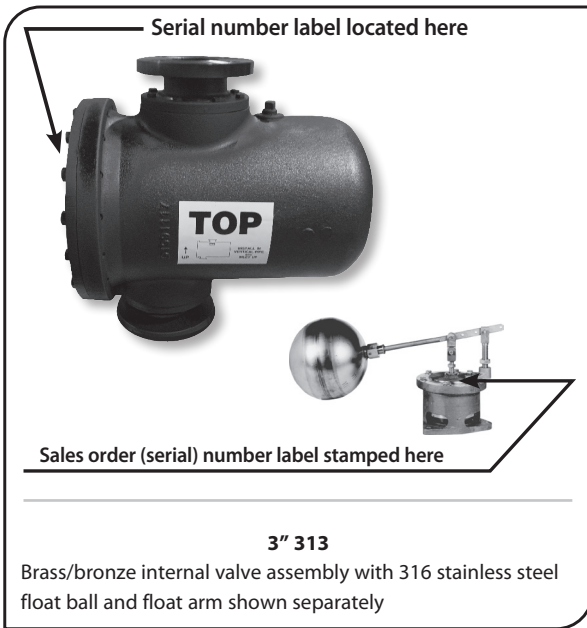

### APPLICATION:

Deaerators, tanks with steam blankets, produce additional liquid as the steam condenses. The 313 Overflow Trap traps and relieves this condensate through its internal pilot without the steam blanket escaping. Buoyancy of its float ball provides force to actuate internal pilot operated single seat valve assembly to relieve condensate and overflow to drain. The overflow trap should be installed in an upright position.

### FEATURES:

Cast Iron Chamber (size 1, 1-1/2, 2, 3 & 4 inch)  
Steel Chamber (size 6 inch), brass/bronze internal valve, 316 stainless steel float ball.  
Sizes 1" through 2" with NPT connections,  
3" & 4" with 125 FF FLG, 6" with 150 RF FLG.  
Large end cover provides easy access to internal valve assembly.

### RATINGS:

System operating pressures to 50 PSIG  
Pressure drops to 15 PSI  
Temperatures to 250F  
Nominal leakage rate 0.1% of rated capacity

### DIMENSIONS AND WEIGHTS :

313	VALVE SIZE IN (MM)																							
	1		(25)		1-1/2		(40)		2		(50)		3		(80)		4		(100)		6		(150)	
A	12-7/8		(328)		18-5/16		(466)		18-5/16		(466)		18-5/16		(466)		20-3/4		(528)		24-5/8		(626)	
B	9		(229)		11-1/4		(286)		11-1/4		(286)		11-1/4		(286)		13-1/4		(337)		16		(407)	
C	6		(153)		7-11/16		(196)		7-1/8		(181)		9-5/16		(237)		11		(280)		12		(305)	
D	5-1/2		(140)		7-11/16		(196)		7-1/8		(181)		9-5/16		(237)		11		(280)		12		(305)	
E	11-1/2		(293)		13-1/2		(343)		13-1/2		(343)		13-1/2		(343)		16		(407)		19-7/8		(505)	
F	3-13/16		(97)		4-11/16		(120)		4-11/16		(120)		4-11/16		(120)		5-3/8		(137)		7-1/2		(191)	
G	4-3/16		(107)		6-11/16		(170)		6-11/16		(170)		6-11/16		(170)		7-5/16		(186)		11-1/2		(293)	
End Connection	THD				THD				THD				125 FLG				125 FLG				150 FLG			
Net Weight (LB)	101				185				183				213				285				336			
Gross Weight (LB)	120				200				200				230				310				370			

### CONDENSATE CAPACITIES:

PRESSURE DROP	POUNDS / HOUR FLASHING CONDENSATE					
	Valve Size (IN)					
(PSI)	1	1-1/2	2	3	4	6
1	4,500	10,800	20,400	35,500	62,000	132,000
2	6,400	15,400	28,700	50,000	88,000	187,000
4	9,000	21,600	40,400	70,500	123,500	262,000
5	10,000	24,000	45,000	78,500	138,000	293,000
7	11,870	28,500	53,300	93,000	163,000	346,000
10	14,200	34,100	63,700	111,200	196,000	415,000
12	15,600	37,400	69,900	122,000	214,500	455,000
15	17,400	41,800	78,200	136,500	239,000	500,800

### ORDERING INFORMATION:

313	Part Number		
Description	Size	End Connection	Part Number
CAST IRON (Size 1-4 inch) OR STEEL (Size 6 inch)	1	NPT	031306XXX002
	1-1/2	NPT	031308XXX002
	2	NPT	031309XXX002
BODY WITH BRONZE TRIM AND 316 ST. STL. FLOAT BALL	3	125 FF FLG	031311XXX002
	4	125 FF FLG	031313XXX002
	6	150 RF FLG	031315XXX001

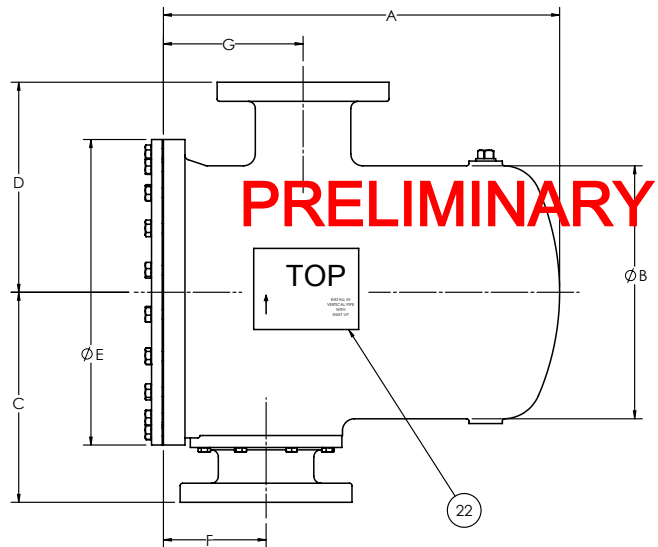

# 200 VACUUM BREAKER

## APPLICATION:

Falling liquid levels and condensing steam can cause a vacuum that can damage a tank. The 200 Vacuum Breaker opens gradually to admit outside air to relieve the vacuum in the tank. The unit must be installed vertically with its mounting connection downward.

## FEATURES:

Iron, steel, or stainless steel body; Iron, steel, or stainless steel seat; Non-asbestos or TFE disc;  
 Size 2" iron with NPT or 125FLG connections,  
 2" steel and stainless steel with 150 or 300FLG;  
 4" through 12" iron with 125FLG,  
 4" through 12" steel and stainless steel with 150 or 300FLG  
 Air relief capacities to 14,280 CFM  
 See What's Available Chart for Features

## PRESSURE-TEMPERATURE RATINGS:

Body: Iron  
 End Connection: 125THD (NPT) and 125FLG  
 Disc: Non-asbestos  
 Maximum Pressure: 50 PSIG  
 Maximum Temperature: 300F

Body: Steel or Stainless Steel  
 End Connection: 150FLG  
 Disc: Non-asbestos  
 Maximum Pressure: 150 PSIG  
 Maximum Temperature: 500F

Body: Steel or Stainless Steel  
 End Connection: 300FLG  
 Disc: Non-asbestos  
 Maximum Pressure: 300 PSIG  
 Maximum Temperature: 500F

## AIR RELIEF CAPACITIES:

Vacuum Inches Of Mercury	200 CFM OF FREE AIR ADMITTED AT 60F SIZE (IN)					
	2	4	6	8	10	12
0.75	88	352	792	1408	2200	3300
0.80	94	376	846	1504	2350	3525
0.85	106	424	934	1696	2650	3975
1.15	126	504	1128	2016	3150	4725
1.25	148	592	1332	2298	3700	5550
1.65	162	648	1458	2592	4050	6780
2.30	188	752	1692	3008	4700	7050
4.00	226	904	2034	3616	5650	8475
4.45	236	944	2124	3776	5900	8850
6.05	268	1072	2412	4288	6700	10050
6.30	276	1104	2484	4416	6900	10350
8.10	300	1200	2700	4800	7500	11250
8.65	314	1256	2826	5024	7850	11775
11.30	334	1336	3006	5344	8350	12525
12.05	348	1392	3132	5568	8700	13050
16.05	370	1480	3330	5920	9250	13875
16.65	372	1488	3348	5952	9300	13950
18.50	386	1541	3481	6189	9670	14505
19.10	381	1523	3427	6093	9520	14280

The Type 200 cannot be set to open at a particular vacuum.  
 The vacuum values presented in the table are for reference only.



Stainless steel stem and non-asbestos disc assembly, Iron body with integral seat and brass guide, and stainless steel spring assembly shown separately

**4" Iron 200**

WHAT'S AVAILABLE		200					
	Features	Size (IN)					
		2	4	6	8	10	12
Body/ Seat	125 THD (NPT) IRON/ IRON	●					
	125 FLG IRON/ IRON	●	●	●	●	●	●
	150 FLG STL/ STL	●	●	●	●	●	●
	300 FLG STL/ STL	●	●	●	●	●	●
	150 FLG ST STL/ ST STL	○	○	○	○	○	○
	300 FLG ST STL/ ST STL	○	○	○	○	○	○
Disc	NON-ASBESTOS	●	●	●	●	●	●
	TFE (TO 200 °F)	○	○	○	○	○	○
Disc holder	STEEL		●	●	●	●	●
	ST STEEL	●	○	○	○	○	○
	REPLACEABLE SEAT ST STEEL	○	○	○	○	○	○
	BIRDSCREEN	○	○	○	○	○	○
	LIFT RINGS	○	○	○	○	○	○

● STANDARD  
 ○ OPTION

## DIMENSIONS AND WEIGHTS :

200		VALVE SIZE IN (MM)											
		2	(50)	4	(100)	6	(150)	8	(200)	10	(250)	12	(300)
A	125THD & FLG	7-1/2	(191)	10-3/4	(273)	12-11/16	(323)	16	(407)	18-3/4	(477)	22-5/8	(575)
	150FLG	7-1/2	(191)	10-1/2	(267)	15-1/2	(394)	17-1/2	(445)	21-1/8	(537)	23	(585)
	300FLG	7-1/2	(191)	11-1/4	(286)	15-1/8	(385)	TBA		21-1/8	(537)	23-1/8	(587)
B	125THD & FLG	11-15/16	(304)	14-1/2	(369)	18-1/8	(461)	19-9/16	(497)	21-1/8	(537)	23-3/8	(594)
	150FLG	13-1/8	(334)	14-7/8	(378)	19-3/16	(488)	20-5/16	(516)	27-3/4	(705)	28-1/2	(724)
	300FLG	13-1/8	(334)	15-1/4	(388)	19-11/16	(500)	TBA		29-1/8	(740)	30-7/16	(763)
Weight (LB)	125THD & FLG	26		68		102		180		230		375	

## ORDERING INFORMATION:

Vacuum Breakers with Non-Asbestos Disc

200 WITH STANDARD TRIM (Integral Seat, Non-Asbestos Disc and Steel Discholder)			
Body Material	Size	End Connection	Part Number
IRON	2*	125FLG	020009EXX000
	2*	NPT	020009IXX000
	4	125FLG	020013EXX000
	6	125FLG	020015EXX000
	8	125FLG	020017EXX000
	10	125FLG	020019EXX007
STEEL	12	125FLG	020020EXX000
	2*	150FLG	020009GXX000
	4	150FLG	020013GXX000
	6	150FLG	020015GXX000
	8	150FLG	020017GXX000
STEEL	10	150FLG	020019GXX000
	12	150FLG	020020GXX000
	2*	300FLG	020009HXX000
	4	300FLG	020013HXX000
	6	300FLG	020015HXX000
	8	300FLG	020017HXX000
STEEL	10	300FLG	020019HXX000
	12	300FLG	020020HXX000

\* 2" Type 200 has stainless steel discholder - standard

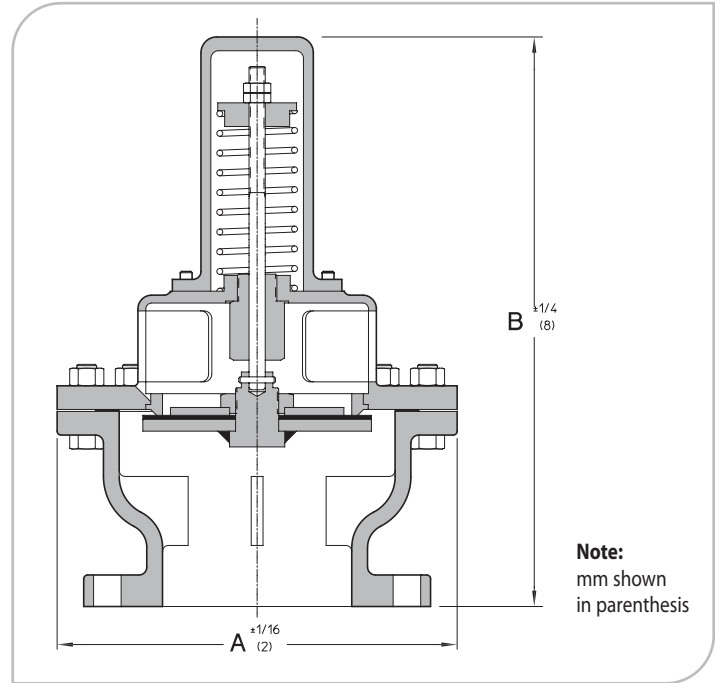

200 WITH NON-ASBESTOS DISC AND STAINLESS STEEL TRIM (SS Discholder and SS Replaceable Seat)			
Body Material	Size	End Connection	Part Number
IRON	2	125FLG	020009EXX006
	2	NPT	020009IXX006
	4	125FLG	020013EXX006
	6	125FLG	020015EXX006
	8	125FLG	020017EXX006
	10	125FLG	020019EXX010
STEEL	12	125FLG	020020EXX006
	2	150FLG	020009GXX006
	4	150FLG	020013GXX006
	6	150FLG	020015GXX006
	8	150FLG	020017GXX006
STEEL	10	150FLG	020019GXX006
	12	150FLG	020020GXX007
	2	300FLG	020009HXX006
	4	300FLG	020013HXX006
	6	300FLG	020015HXX006
	8	300FLG	020017HXX006
STEEL	10	300FLG	020019HXX006
	12	300FLG	020020HXX006

# 200 VACUUM BREAKER

## ORDERING INFORMATION:

Vacuum Breakers with Teflon Disc

<b>200</b>			
<b>WITH INTEGRAL SEAT, TEFLON DISC, AND STEEL DISCHOLDER</b>			
<b>Body Material</b>	<b>Size</b>	<b>End Connection</b>	<b>Part Number</b>
IRON	2*	125FLG	020009EXX001
	2*	NPT	020009IXX001
	4	125FLG	020013EXX001
	6	125FLG	020015EXX001
	8	125FLG	020017EXX001
	10	125FLG	020019EXX008
STEEL	12	125FLG	020020EXX001
	2*	150FLG	020009GXX001
	4	150FLG	020013GXX001
	6	150FLG	020015GXX001
	8	150FLG	020017GXX001
	10	150FLG	020019GXX001
STEEL	12	150FLG	020020GXX001
	2*	300FLG	020009HXX001
	4	300FLG	020013HXX001
	6	300FLG	020015HXX001
	8	300FLG	020017HXX001
	10	300FLG	020019HXX001
12	300FLG	020020HXX001	

\* 2" Type 200 has stainless steel discholder - standard

<b>200</b>			
<b>WITH TEFLON DISC, AND STAINLESS STEEL TRIM (SS Discholder and SS Replaceable Seat)</b>			
<b>Body Material</b>	<b>Size</b>	<b>End Connection</b>	<b>Part Number</b>
IRON	2	125FLG	020009EXX004
	2	NPT	020009IXX004
	4	125FLG	020013EXX004
	6	125FLG	020015EXX004
	8	125FLG	020017EXX004
	10	125FLG	020019EXX009
STEEL	12	125FLG	020020EXX004
	2	150FLG	020009GXX004
	4	150FLG	020013GXX004
	6	150FLG	020015GXX004
	8	150FLG	020017GXX004
	10	150FLG	020019GXX004
STEEL	12	150FLG	020020GXX004
	2	300FLG	020009HXX004
	4	300FLG	020013HXX004
	6	300FLG	020015HXX004
	8	300FLG	020017HXX004
	10	300FLG	020019HXX004
12	300FLG	020020HXX004	

# TERMS & CONDITIONS OF SALE

WARREN CONTROLS INC. (Hereinafter called "Seller") agrees to supply the equipment covered herein on the following terms and conditions. Additional terms and conditions not covered herein will be accepted only upon mutual agreement in writing.

**ORDERS:** Contracts and orders are subject to acceptance by the home office of the Seller.

**FREIGHT TERMS:** All Prices are FOB factory (Bethlehem, PA).

**MINIMUM ORDER REQUIREMENT:** All orders must have a minimum net value of \$400.

**PRICES AND DISCOUNTS:** All prices and discounts are in accordance with the established price and discount schedules of the Seller, and are subject to change without notice.

**PRICE LIST:** The price list is not an offer to sell to any person who possesses it, nor to anyone else, the goods listed herein at the prices shown. All prices herein set forth supersede all prior price lists and are subject to change without notice. Warren Controls Incorporated may also, from time to time, discontinue, without notice, the sale of any of the products herein.

**TAXES:** The amount of any present or future sales, use, occupancy, excise, or other tax, federal, state or local, which the Seller now, or hereafter shall be legally obligated to pay, either on its own behalf or on the behalf of the purchaser or otherwise, with respect to the material covered by this order or contract, shall (unless the prices contained herein are stated expressly to include such tax) be added to such prices and paid by the purchaser. Purchaser agrees to report and pay any such tax directly on any non-exempt transaction, when Seller's invoices do not indicate such a charge.

**REMITTANCES:** All invoices shall be due and payable in United States currency, free of exchange, collection, or any other charges, net 30 days, or as otherwise agreed upon and set forth in writing by Seller. Past due invoices are subject to a carrying charge of 1% per month. The purchaser, if so requested, agrees to furnish Seller with all information, including financial statements, necessary to make proper credit appraisal. Refusal to supply such information may cause a quotation to be withdrawn. Quotations for extended periods are subject to change with reasonable notice.

**LIABILITY:** The buyer shall remain primarily liable for the purchase price and the Seller shall not be obliged to accept any term or condition of payment which will shift liability to a third person not a party to the contract of sale, whether or not such third person is the United States Government, its agents or instrumentalities.

**RUSH ORDERS:** Expediting is something that we at Warren Controls Incorporated endeavor to accommodate whenever possible but must be requested and promised on a case-by-case basis. Premium freight is not assumed and must be specified on the purchase order.

**DISCONTINUANCES OF DELIVERIES:** Should the purchaser's financial responsibility be or become unsatisfactory to the Seller, cash payment or satisfactory security at any time may be demanded by the Seller, and if not furnished to the Seller's satisfaction, the Seller may at its option discontinue deliveries and charge the purchaser for the sale value of any completed or partly completed articles manufactured pursuant to the order or contract.

**PARTIAL SHIPMENTS:** Seller reserves the right to make partial shipments from time to time and render invoices therefore, which shall be due and payable as provided in paragraph entitled "Remittances".

**DELAYS:** The Seller shall not be liable for any loss, damage, or delay occasioned by any causes beyond the Seller's control, including, but not limited to governmental actions or orders, embargoes, strikes, differences with workers, fires, floods, accidents, or transportation delays. IN NO EVENT SHALL SELLER BE LIABLE FOR ANY CONSEQUENTIAL OR SPECIAL DAMAGES.

**WEIGHTS AND DIMENSIONS:** Shipping weights and dimensions given in catalogs and drawings are as close to actual as practicable but are not guaranteed. No claims will be allowed because of any discrepancy between actual weights or dimensions of material shipped and listed data in catalog.

**SHIPPING AND PACKING:** All material is carefully packed for shipment and Seller will not be responsible for loss, delay or breakage after having received "in good order" receipts from the transportation company. All claims for breakage, loss, delay and damage should be made to carriers, but Seller will render all possible assistance in securing satisfactory adjustment of such claims. Goods will be shipped by the method and via carrier Seller believes dependable, unless the buyer designates the carrier. Goods held at factory beyond delivery date for convenience of buyer will be invoiced on date of completion and terms of payment will apply as from invoice date. Such goods will be subject to charges for warehousing and other expenses incident to such delay.

**REJECTION OF SHIPMENT:** If the purchaser is unable or unwilling to accept any shipment, the purchaser shall be liable to the Seller, in addition to any other rights for which the Seller may be entitled, for freight, express, storage, extra cost of handling, and other expenses incurred thereby.

**CANCELLATION:**

All orders are firm and are not subject to cancellation or change in specifications, shipping schedules or other conditions without Seller's written consent, which will be given only upon agreement to compensate for loss caused by such cancellation or changes.

**SHORTAGE CLAIMS:** Claims for shortage or incorrect filling of orders must be made within 60 days from date of delivery.

**WARRANTY:** The Seller warrants that the equipment manufactured by it and covered by this order is free from defects in material and workmanship and, without charge, product found to be defective in material or workmanship will be repaired, or at Seller's option replaced F.O.B. original point of shipment, if written notice of failure is received by Seller within one (1) year after date of shipment (unless specifically noted elsewhere), provided said product has been properly installed, operated in accordance with the Seller's instructions, and provided such defects are not due to abuse or decomposition by chemical or galvanic action. THIS EXPRESS WARRANTY IS IN LIEU OF AND EXCLUDES ALL OTHER WARRANTIES, GUARANTEES, OR REPRESENTATIONS, EXPRESS OR IMPLIED. THERE IS NO IMPLIED WARRANTY OF MERCHANTABILITY OR OF FITNESS FOR A PARTICULAR PURPOSE. Seller assumes no responsibility for repairs made on the Seller's equipment unless done by the Seller's authorized personnel, or by written authority from the Seller. The Seller makes no guarantee with respect to material not manufactured by it. Seller shall not be liable for consequential damage in case of any failure to meet the conditions of any guarantee or shipping schedule, nor will claims for labor, loss of profits, repairs or other expenses incidental to replacement be allowed. The Seller in connection with the manufacture and sale of its equipment makes no other representation, guarantee or warranty, expressed or implied.

**PURCHASER'S REMEDIES:** The purchaser's remedies with respect to equipment manufactured by Seller covered by this order or contract and found to be defective shall be limited exclusively to the right of repair or replacement of such defective equipment. IN NO EVENT SHALL SELLER BE LIABLE FOR CLAIMS (BASED UPON BREACH OF CONTRACT, BREACH OF EXPRESS OR IMPLIED WARRANTY, OR NEGLIGENCE) FOR ANY OTHER DAMAGES, WHETHER DIRECT, IMMEDIATE, FORESEEABLE, CONSEQUENTIAL, OR SPECIAL OR FOR ANY EXPENSES INCURRED BY REASON OF THE USE OR MISUSE, SALE OR FABRICATION OF PRODUCTS WHICH DO OR DO NOT CONFORM TO THE TERMS AND CONDITIONS OF THIS ORDER OR CONTRACT.

**CONSEQUENTIAL DAMAGES:** IN NO EVENT SHALL BUYER BE ENTITLED TO RECOVER ANY CONSEQUENTIAL OR INCIDENTAL DAMAGES, INCLUDING BUT NOT LIMITED TO ANY COMMERCIAL LOSS OR INJURY TO ANY PERSON, WHETHER OR NOT SAID DAMAGES ARE CAUSED, IN WHOLE OR IN PART, BY ANY DELAY, FAILURE, NONPERFORMANCE OR NEGLIGENCE OF SELLER, OR THE BREACH BY SELLER OF ANY OF THE TERMS OF SALE CONTAINED HEREIN OR ANY OTHER TERM OR CONDITION MADE A PART OF THE CONTRACT BETWEEN SELLER AND BUYER.

**RETURNS:** Return material shipments shall be prepaid and clearly marked with a Sales Shipping Authorization (SSA) number issued by the Seller. Items returned for repair shall include detailed information about the application/installation, and the nature of the trouble experienced. Credit may be issued by the Seller for unused, current product, returned in saleable condition, after deduction of a restocking fee, typically 25% of the purchase price. Warranty coverage, or credit consideration, will be determined only after receipt and inspection of the material by the Seller.

**BOND PREMIUMS:** In the event the Seller shall be required as a condition of the manufacture and sale of equipment to furnish a performance bond, the buyer shall pay as a part of the purchase price of said equipment all bond premiums and expense in connection therewith.

**DESIGNS:** All designs and specifications shown in Seller's catalog are subject to change without notice.

**PATENT INFRINGEMENT:** The Seller will hold the purchaser and user harmless from infringement of any United States patent covering equipment of its manufacture. This, of necessity, is limited to the equipment per se and cannot be extended to applications of such equipment by others. The purchaser and user shall advise the Seller immediately in the event any claims of infringement are brought to their attention.

**COMPLIANCE WITH LAWS:** Seller has complied with all applicable Federal, State and local laws and regulations in connection with the manufacture and sale of all equipment. No responsibility or liability will be taken for import duties, laws, regulations or taxes imposed by any foreign country.

**GOVERNING LAW:** This contract shall be governed by, construed, and enforced in accordance with the laws of the State of Pennsylvania.

**ERRORS:**

All clerical errors are subject to correction.

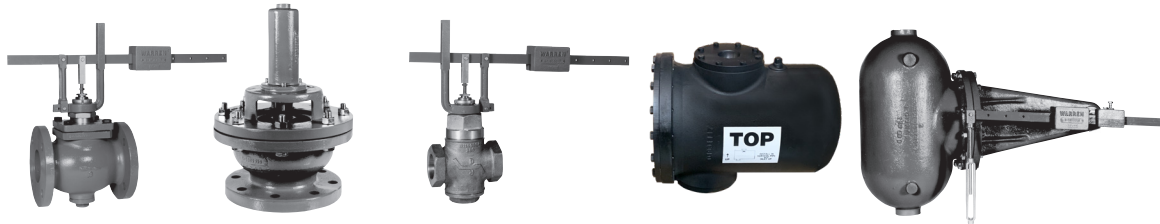

LEVEL CONTROLS PRODUCT SPEC

**WARREN CONTROLS**

2600 EMRICK BLVD • BETHLEHEM, PA 18020 • USA • 800-922-0085 • WWW.WARRENCONTROLS.COM  
DEPENDABLE, RUGGED, PRECISION CONTROL VALVES AND ACCESSORIES

Level Controls\_PS\_RevI\_1023